

# MOBACO

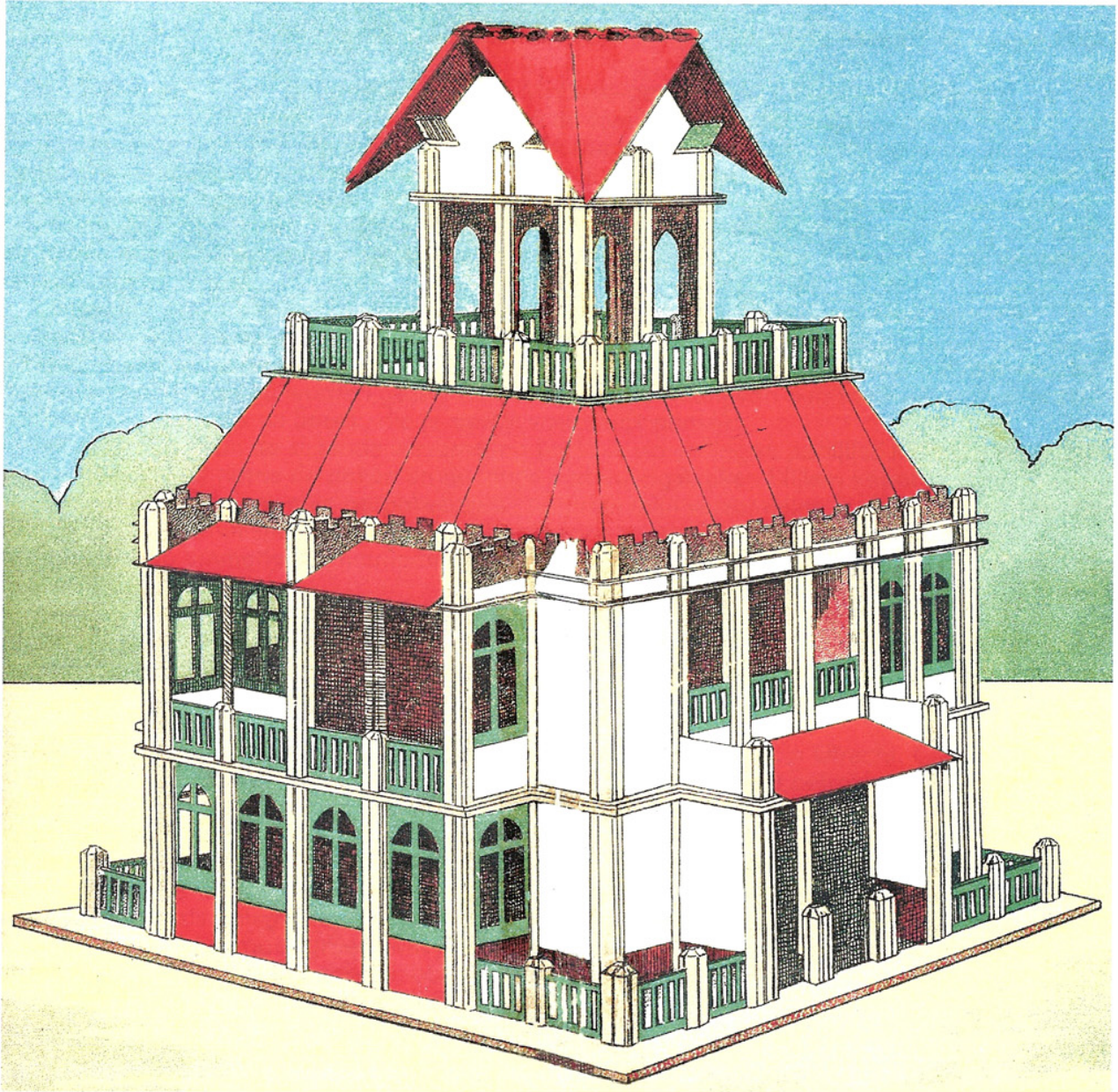

T.M.Halbertsma - Text 18 oktober 2008

# MOBACO

## INLEIDING

In de jaren negentien dertig was Mobaco geliefd speelgoed in mijn ouderlijk huis aan de Hazepaterslaan 7 in Haarlem. Op een grondplaat werden in gaten vierkante paaltjes met groeven rechtop gezet. Tussen de rechtopstaande paaltjes werden deuren, ramen en muren in de groeven geplaatst. Door platte daken en verbindingsbalken met vierkante gaten werden de palen met de ramen en deuren bijeengehouden. Op de platte daken konden ook schuine rode daken worden geplaatst. Deuren, ramen, muren en daken waren gemaakt van geperst karton van 2 ½ millimeter dikte.

Er zijn nog resten Mobaco uit die tijd over, onder andere ramen met ronde hoeken bovenin en paarse daken.

In 1938 kreeg ik een bouwdoos voor een Mobaco-garage. Na de oorlog heb ik nog wat los materiaal Mobaco en langere palen gekocht. Van de familie Schreuder in Leeuwarden kreeg ik hun oude restant-verzameling Mobaco, die bij hun verhuizing anders zou zijn weggegooid. Daaronder bevond zich een molen en een tweede, grotere garage. In ons familie-fotoboek over 1963 staat een foto van mijn zoon Tjalling Binnert Halbertsma in onze zitkamer in Grou, met een tot het plafond opgebouwde Mobaco-toren. Tenslotte heeft timmerman van Royen uit Bennebroek een groot aantal palen in alle maten bijgemaakt, plus nog wat extra lange palen van circa 53 centimeter, die precies in een opbergkist passen.

Omstreeks 2003 blijken mijn kleinkinderen bij logeerpartijen bij hun pake en beppe in Heemstede opnieuw fervent te spelen met dit inmiddels al 45 jaar niet meer geproduceerde speelgoed. Eerst wordt een molton over de rechthoekige, uitgetrokken eiken tafel gelegd, waarna de doosjes met Mobaco er op worden gezet, vlak onder het schilderij van hun betovergrootvader Hylke Halbertsma met het sikje uit Sneek, die je steeds vriendelijk aankijkt.

Ter aanvulling van de slijtende verzameling kocht ik via veilingen partijtjes Mobaco en enkele complete dozen. Met name de daken en de lange verbindingsbalken blijken kapot te gaan. Naar ik hoop zullen over vijftig jaar mijn oerpakesizzers<sup>1</sup> nog met mijn verzameling kunnen spelen. Daartoe dient de Mobaco na het spelen weer netjes opgeborgen te worden in de door mijzelf in de wereldoorlog II op timmerles bij timmerman Noë<sup>2</sup> te Haarlem gemaakte kist, en in allerlei opbergdoosjes.

Van de geschiedenis van Mobaco ben ik het volgende aan de weet gekomen:

Op 1 December 1915 richtten de heren C.W. Bal en P. van Mouwerik de vennootschap onder firma Plaatmetaalindustrie Van Mouwerik & Bal (later in de wandeling Mobal of Moubal) op. Deze naam bleef ongewijzigd na het overlijden van van Mouwerik in 1925; Bal voerde het bedrijf alleen verder.

De fabricage van metalen onderdelen van allerlei aard en soort startte in Utrecht. Omstreeks 1919 werd een nieuw fabrieksgebouw van 14000 m<sup>2</sup> aan de Dalweg te Zeist betrokken, bij de overweg van de inmiddels opgeheven spoorlijn Utrecht-Bilthoven-Huis ter Heide-Zeist.

De vennootschap onder firma werd omgezet in een naamloze vennootschap. Meer dan 100 arbeiders vervaardigden talloze producten. Omstreeks 1920 werd een speelgoed-bouwdoos ontworpen en in de handel gebracht onder de naam Mobaco. Enkele malen per jaar werd de gewone productie stil gelegd om Mobaco te produceren. Het gebruikte materiaal was hardcarton, in de kleuren donkergrijs, rood, groen, wit, geel. Tot omstreeks 1934 was het paars-rood, daarna knalrood. Het groen had aanvankelijk ook diverse kleur-nuances. Aanvankelijk werden ook gekleurde lagen op donker carton geperst. Het carton werd op de goede grootte gebracht, en er werden gaten in gestanst. In de cartonnen onderdelen werd een nummer geperst.

Mobaco werd via de speelgoedhandel verkocht.

Vermoedelijk werd in de jaren twintig begonnen met het aanbieden van twee dozen met de nummers 1 en 2 met een kleinere en een grotere inhoud. Het hierachter opgenomen voorbeeldenboek van doos 2 uit de beginjaren toont grote bouwwerken; er moet dus een groot aantal onderdelen in hebben gezeten.

<sup>1</sup> Hopelijk verstaan mijn oerpakesizzers over 50 jaar voldoende Fries, om te weten wat dit woord betekent.  
<sup>2</sup> Timmerman Noë is in de familie bekend als mijnheer Kerstmis zonder 1.

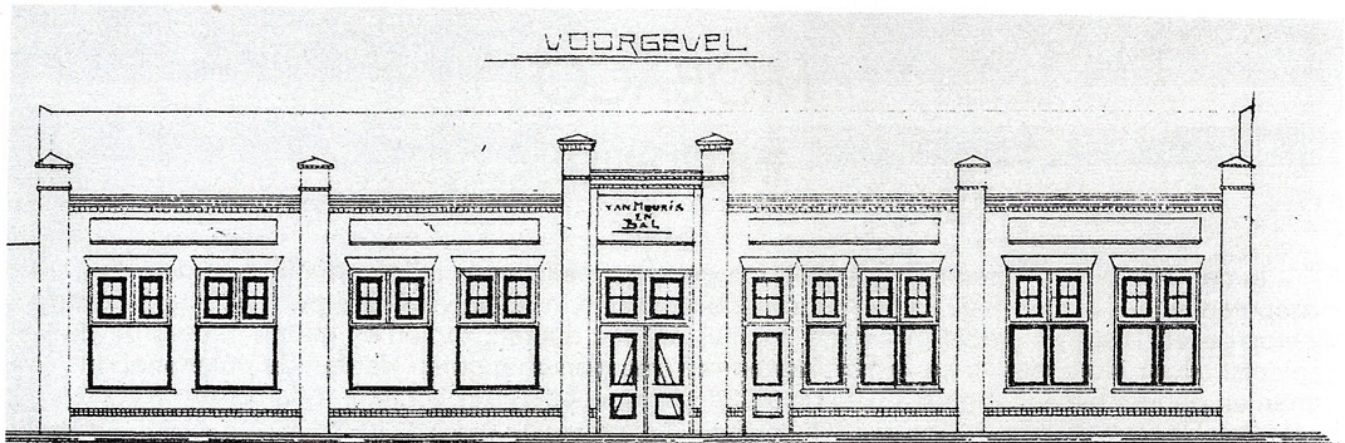

Voorgevel fabrieksgebouw van Mouwerik en Bal aan de Dalweg te Zeist - Bouwtekening 1919

Na enkele jaren, maar al vóór 1934 werd het aantal verschillende te koop aangeboden dozen flink uitgebreid, terwijl tevens in een kennelijke behoefte aan goedkope begindozen werd voorzien. Er werd een nieuwe nummering ingevoerd. Volgens een prijslijst uit die jaren werden "bouwdoozen" genummerd 000, 00, 0, 01, 1, 1a, 2, 2a, 3 en 4 aangeboden, geprijsd tussen fl 0,75 en fl 42,-. Dat laatste bedrag was voor die tijd een enorme som.

De tussendoos 01 of 0A completeerde de doos 0 tot doos 1; evenzo de dozen 1a en 2a.

Tussen 1925 en 1934 wordt als noviteit een molen in twee grootten gemaakt, en in een folder aangeprezen. De hiervoor al genoemde prijslijst<sup>3</sup> vermeldt een "Station-1" en "Station-2", alsmede een "Garage-1" en een "Garage-2" (maar niet meer de molen). Voor deze noviteiten werd gebruik gemaakt van het bestaande materiaal aangevuld met enkele nieuwe stukken. Blijkbaar was de verkoop van de molen, station en garage onvoldoende, want deze artikelen verdwenen enkele jaren later weer uit de collectie<sup>4</sup>.

Bij de verschillende dozen hoorden voorbeeldenboekjes. Enkele van deze boekjes zijn gereproduceerd.

Aanvankelijk was de verkoop van Mobaco een commerciële succes, ook in het buitenland getuige de Franse, Engelse en Spaanse opschriften op de dozen.

Omstreeks 1950 kwam het veel goedkoper te produceren plastic speelgoed Lego aan de speelgoedmarkt. Bovendien konden kleine kinderen sneller met het nieuwe Lego aan de slag dan met het moeilijker Mobaco. De fabrikant trachtte nog vergeefs het getij te keren door op basis van het bestaande materiaal kleinere modellen ramen en deuren te maken, en de verkoop in kleinere dozen uit te besteden aan de spelletjesfabriek Jumbo van de fa Hausemann & Hötte. Geen werkelijke vernieuwing echter. Omstreeks 1960 werd de productie van Mobaco gestaakt.

Helaas blijken bij navraag geen archiefstukken van de fabriek, die in 1981 failliet ging, te zijn ondergebracht in het algemene archief van de gemeente Zeist. Bij naspeuringen door de heer A. Geelhoed in het archief van de gemeente Zeist zelf kwam de bouwaanvraag met een paar bouwtekeningen van de fabriek tevoorschijn, alsmede enkele krantenartikelen, die verschenen waren bij het gouden fabrieksjubileum in 1965 en bij de faillissementsaanvraag. Misschien wordt later nog ergens anders toevallig de speld in de hooiberg gevonden, zodat alsnog wat fabrieksgegevens tevoorschijn komen. Ik ving ooit op, dat Mobaco-verzamelaars verhalen van oud-personeelsleden hebben opgetekend. Op Internet heb ik een website van de Engelsman Lilleker met een verhaal over Mobaco aangetroffen.

Voorzover ik heb kunnen reconstrueren, heeft Mobaco van het begin (omstreeks 1920) tot het eind (omstreeks 1960) steeds dezelfde hardcartonnen bouwelementen - grondplaten, palen, ramen, deuren, muren, daken, verbindingsstroken - gefabriceerd. Onder "Materiaal overzicht" is een totaaloverzicht van alle mij bekende onderdelen met hun Mobaco-nummers opgenomen. In de loop der jaren werden enkele nieuwe daken en bomen aan de oorspronkelijke collectie toegevoegd.

<sup>3</sup> De wat gezwollen tekst doet vermoeden dat de molen-folder vóór de prijslijst is geschreven. Beiden zijn in de spelling-de Vries en te Winkel. Conclusie: de molen-folder moet gedateerd worden tussen circa 1925 en 1934; de prijslijst moet van 1934 zijn.

<sup>4</sup> Wanneer zij uit de collectie verdwenen is niet bekend.

Slechts enkele wijzigingen van bestaande onderdelen zijn mij bekend: de afgeronde bovenramen no.20 werden omstreeks 1930 gewijzigd in rechthoekige bovenramen. In de "Jumbo-jaren" van circa 1950 tot 1960 (met in het algemeen lagere bouwsels) werden deze ramen door een lager, geel model 19 vervangen. Half-hoge deuren 54 vervingen de deuren hoog model 14. Merkwaardigerwijze bleven de oude kerkramen hoog model 15 gehandhaafd, en in de Jumbo-dozen bij de lagere elementen gestoken. Voor de molens en de garages werd een aantal aparte ongenummerde onderdelen vervaardigd. Als bijzonderheid voor de garages werden de ramen 20 onder hetzelfde nummer, de deuren 14 onder een nieuw nummer 19, en de hekjes 24 onder hetzelfde nummer maar allen in een gele uitvoering vervaardigd. De gele hekjes en ramen werden later af en toe ook los aangemaakt.

In de Jumbo-tijd van 1950-1960 werd het aanbod verpakt in de dozen A, B, C, D en E. Doos AB completeerde doos A tot doos B; idem dozen BC, CD en DE.

In de deksel werd een inhoudsopgave van de dozen geplakt.

De diverse onderdelen werden ook los en per stuk te koop aangeboden. De hiervoor genoemde prijslijst vermeldt de winkelprijzen; dan kon nog in een tijd zonder Brussel'se verticale prijsbinding.

In dit boekje zijn de volgende reproducties van Mobaco-materiaal opgenomen:

- Voorbeeldenboeken bij de bouwdozen 000, 00, 0 en 1. De oudere uitgaven tonen de ramen met ronde hoeken boven, en latere ramen met rechte hoeken.
- Groot Voorbeeldenboek bij de oude doos 2. Het grote boek met het formaat 30x45 voor de grote doos 2 had dezelfde inhoud als de kleine boekjes, met aanvulling van een twintigtal grotere gebouwen. Voor- en achterkant waren in meerkleurendruk.
- Voorbeeldenboek uit de jaren 19-vijftig voor de dozen A-E.
- Folder en foto van de molen.
- Foto's en doos van de garage's.
- Diverse deksels van dozen en verpakkingen.
- Algemene overzichten en binnen in de deksels van dozen ingeplakte overzichten van de Mobaco-onderdelen.
- Folder met overzicht van verkrijgbare bouwdozen en onderdelen.
- Een website-artikel van Lilleker.
- Op de slotpagina treft u een foto aan van een Mobaco-gebouw genaamd "De Bullenburg".

De geschiedenis van "De Bullenburg" is als volgt:

Vóór Wereldoorlog 2 speelden mijn vriend Otto ter Haar en ik met Mobaco op de grote zolder van mijn ouderlijk huis aan de Hazepaterslaan 7 te Haarlem. Telkens verrees "De Bullenburg" in een andere gedaante. Het gebouw diende in de fantasie van Otto tot onderkomen van de rijke oom, die een kranke neef herbergde. Uiteraard werd door mij een spoorweg naar de Bullenburg aangelegd om voor adaequaat vervoer van de diverse familieleden van de rijke oom te zorgen.

Onvermijdelijk diende de zolder af en toe opgeruimd te worden en moest de "Bullenburg" worden afgebroken. Mijn moeder hielp vaak met het opbergen van de Mobaco - een dierbare herinnering. In de loop der jaren sneuvelden af en toe onderdelen of dozen. Als reminiscentie aan gelukkige kinderjaren leek het gepast om 65 jaar later een nieuwe versie van de aloude "Bullenburg" te bouwen en te fotograferen<sup>5</sup>.

De diverse drukwerken, afbeeldingen en dozen zijn met behulp van computer en scanner gereproduceerd. Omdat het groot voorbeeldenboek nummer 2 deerlijk verminkt was, heb ik met graagte van een retoucheer-programma van Adobe gebruik gemaakt. Vele (niet alle) vouwen, scheuren, krassen en vergeeld plakband konden daarmee worden weggewerkt. Het oorspronkelijke dubbel folio formaat moest worden vervangen door het hedendaagse A4.

Heemstede, 2003-2005

mr T.M.Halbertsma

---

<sup>5</sup> In de loop der jaren werd duidelijk, dat Otto eigenlijk zelf de rijke oom was, die met gulle hand talloze kranke neven in steeds nieuwe gedaanten begiftigde. Die kranke neven waren allereerst ikzelf; vervolgens verliezers bij Monopoly, die hij als lakei aanstelde en bij het passeren van Go een extra salaris van hem kregen zodat het spel voort kon gaan (Otto placht alle spelletjes te winnen). Daarna straatschoffies rond zijn studentenkamer in Leiden die woensdagmiddag snoepjes kregen uitgedeeld, en zijn studievrienden, die kwistig alcoholhoudende drank kregen aangeboden - vooral als zijn oom Ben de sociëteit Minerva als reünist had bezocht, of als hij bij zijn grootouders in Epe had gelogeed. Daar gaf oma hem geld onder voorwaarde dat hij het niet aan opa zou vertellen, en gaf opa hem geld onder voorwaarde dat hij het niet aan oma zou vertellen - . In zijn later leven werden vele logé's en gasten begiftigd; en velen die hij in en buiten zijn werk voorthielp.

# VOORBEELDENBOEK 000

Omstreeks 1934. Eenvoudige zwartdruk zonder omslag. Verkleind.

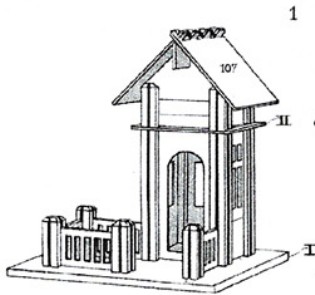

**MOBACO**  
**No. 000**

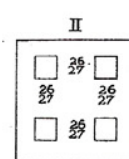
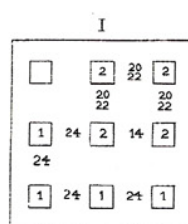
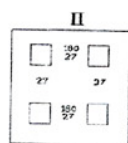
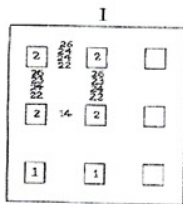
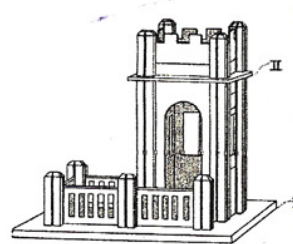
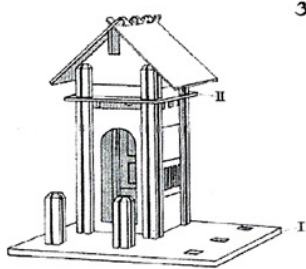
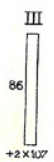
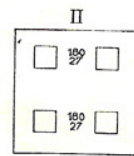
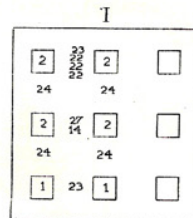
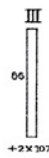
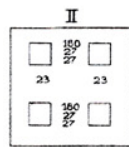
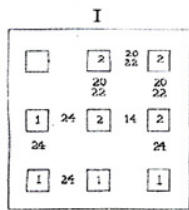
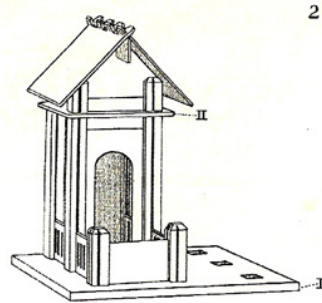

# VOORBEELDENBOEK 0-1

Voorbeeldenboekje met rechthoekige ramen, spelling Marchand, omstreeks 1935.  
Rechthoekige ramen. Tweekleurendruk. Iets verkleind.



## AANWIJZINGEN VOOR HET BOUWEN MET M O B A C O.

Zoals men elk huis begint met de fundering, begint men bij het bouwen met MOBACO met de grondplaat, waarin zich verschillende vierkante gaten bevinden. In deze gaten passen de gegroefde houten paaltjes. De groeven in deze paaltjes dienen om het mogelijk te maken dat de gekleurde cartonnen onderdelen hierin op en neer kunnen schuiven, en aldus een verbinding vormen tussen de palen.

Alle onderdelen zijn voorzien van nummers, terwijl bovendien elk onderdeel in zijn eigen kleur is afgedrukt in de deksel van elke doos, waardoor het zeer gemakkelijk is aardige huisjes te bouwen volgens de plattegronden, welke door corresponderende nummers aanwijzingen geven.

Nadat dus de grondplaat gelegd is, en de palen zijn opgezet, schuift men de gekleurde stukjes carton tussen de palen, volgens Fig. I van de plattegrond. Fig. II en III vormen steeds de vloer van de 1e verdieping. Voor het construeren der verdere verdiepingen geven de plattegronden steeds praktische aanwijzingen.

Wat betreft het plaatsen der cartonnen delen, geeft het onderste getal op de plattegrond steeds het onderste cartonnen deel aan, terwijl het bovenste nummer steeds het daarop te plaatsen deel aangeeft; dit gaat dus in volgorde van het bouwen.

Het spreekt van zelf dat men ook volgens eigen inzicht kan bouwen, hetgeen MOBACO des te aantrekkelijker maakt, en dus voor alle leeftijden een zeer praktisch, leerzaam en aangenaam speelgoed is.

Losse onderdelen zijn steeds verkrijgbaar.

Dozen 1, 1 A, 2, 2 A en 3 vullen elkaar aan en vormen dus een ketting.

$1 + 1A = 2$ ;  $2 + 2A = 3$ ;  $1 + 1A + 2A = 3$ .

## VOORBEELDENBOEK 00-0-1

Voorbeeldenboekje met ronde bovenramen uit de jaren 1920. Voorblad omslag.  
Curieus is, dat er zowel boekjes zijn met een omslag en met een inhoud met ronde bovenramen, als boekjes met rechthoekige ramen op het omslag, maar met ronde bovenramen in de inhoud, alsook boekjes met rechthoekige ramen op de omslag en binnenin. Blijkbaar is de overgang van de ronde bovenramen naar rechthoekige ramen slechts langzaam aan gegaan.



Voorbeeldenboekje met rechthoekige ramen. Voorblad omslag.  
Omstreeks 1930-1950. Driekleurendruk.





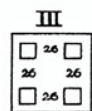
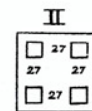
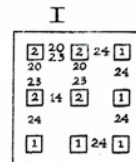
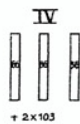
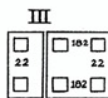
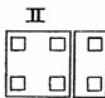
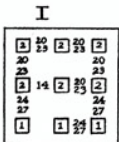
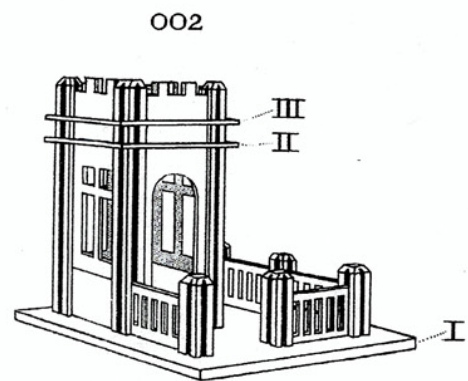
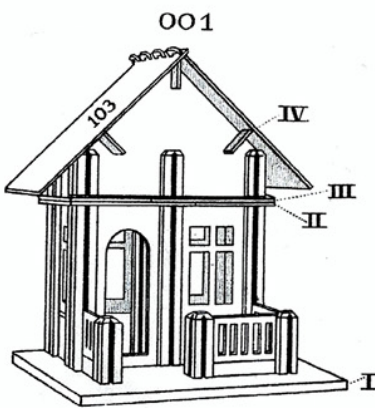
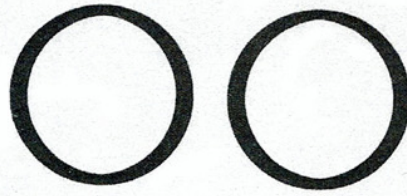

003

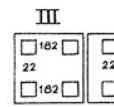
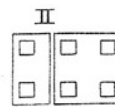
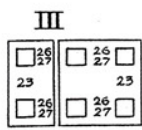
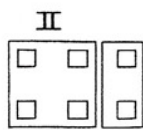
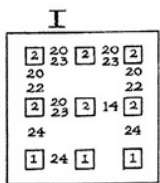
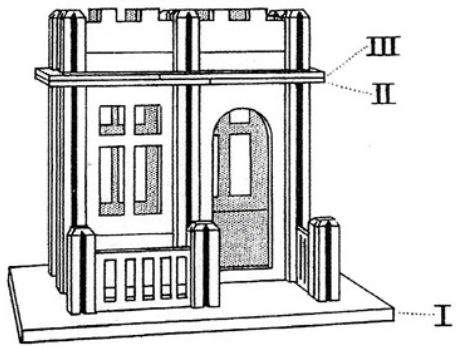

005

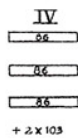
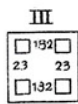
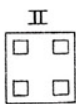
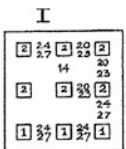
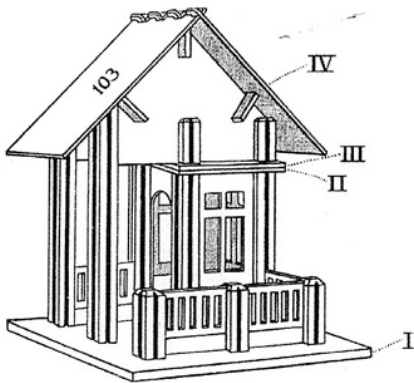

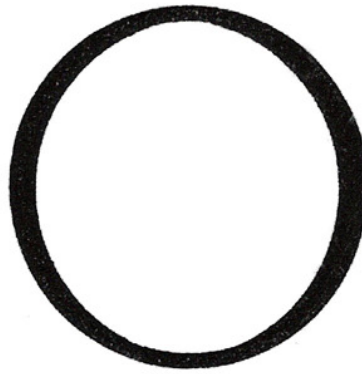

O1

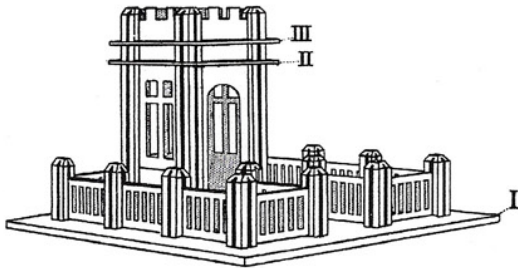

O2

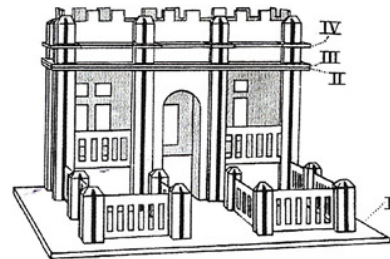

I

1	24	2	20	2	24	1
24	20	22	20	24	24	
1	2	14	2	1	1	
24				24		
1	1	1	1	1	1	
24	24	24	24	24	24	
1	24	1	1	24	1	

II

□	27	□
□	27	27
□	27	□

III

□	26	□
□	26	26
□	26	□

I

20	23	23	23	23	23
20	23	23	23	23	23
23	23	14	23	23	23
24				24	
□	□	□	□	□	□
24	24	24	24	24	24
1	24	1	1	24	1

II

□	□	□	□
□	□	□	□

III

□	27	□	27	□	27	□
□	27	□	27	□	27	□

IV

□	26	□	26	□	26	□
□	26	□	26	□	26	□

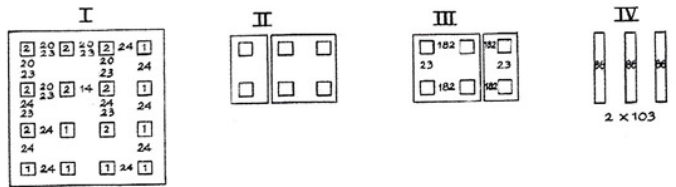
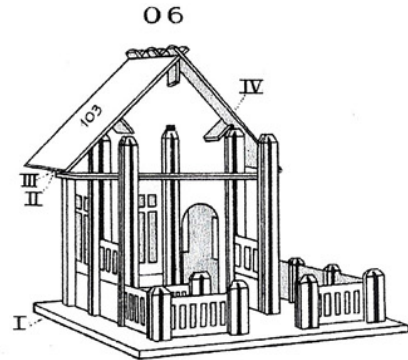
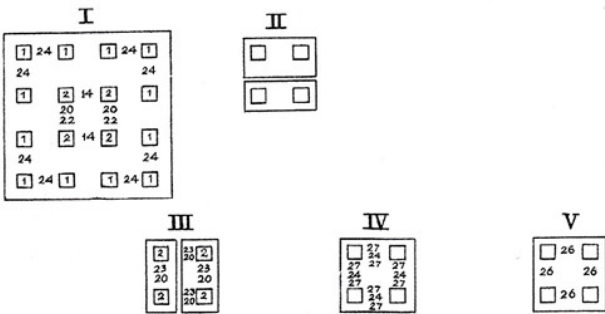
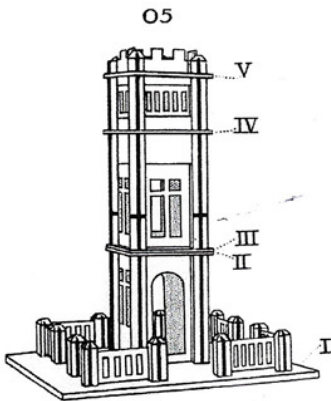
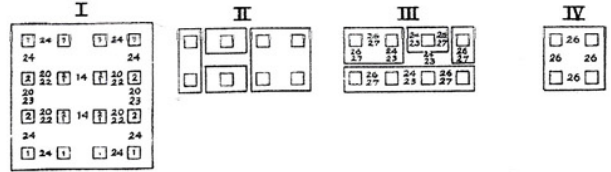
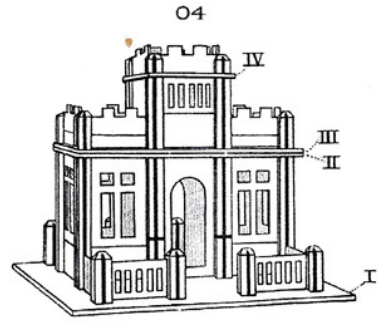
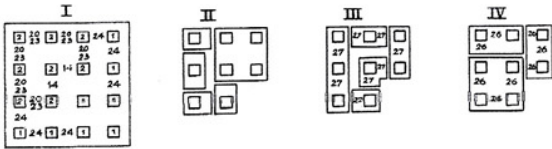
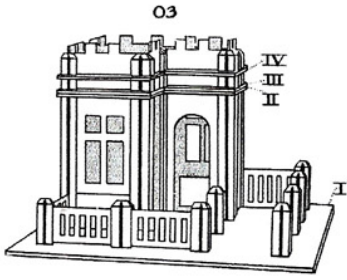

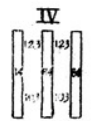
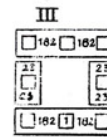
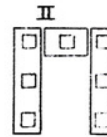
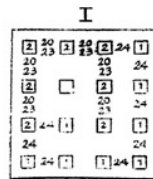
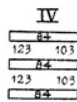
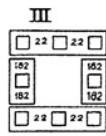
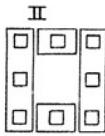
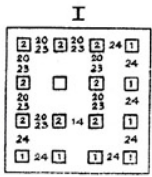
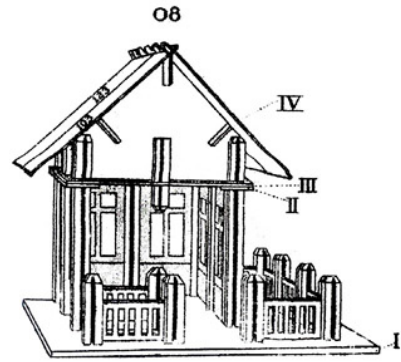
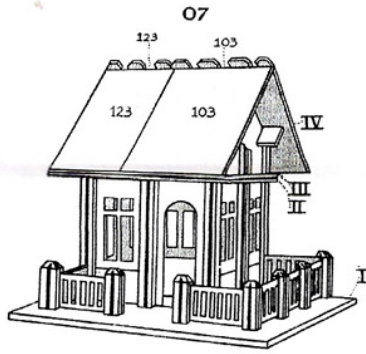

1

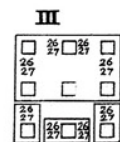
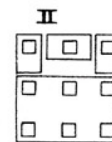
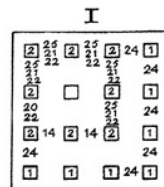
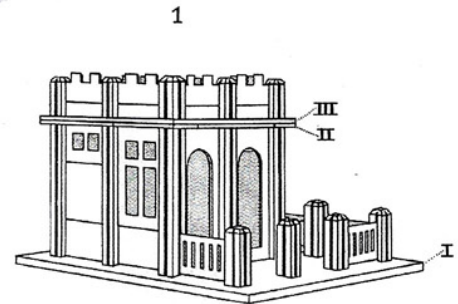

1

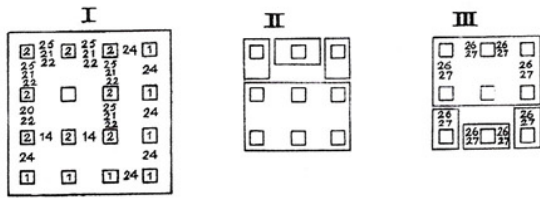
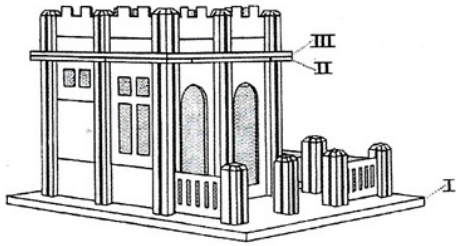

2

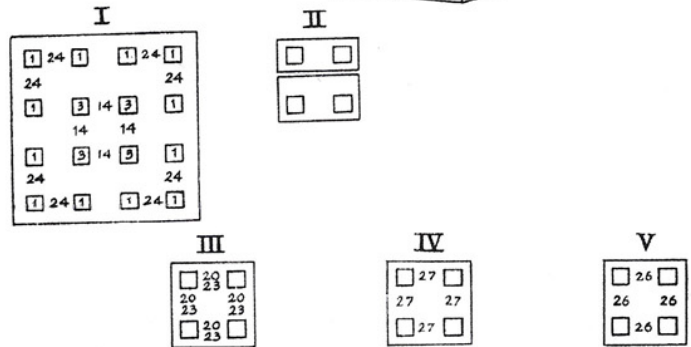
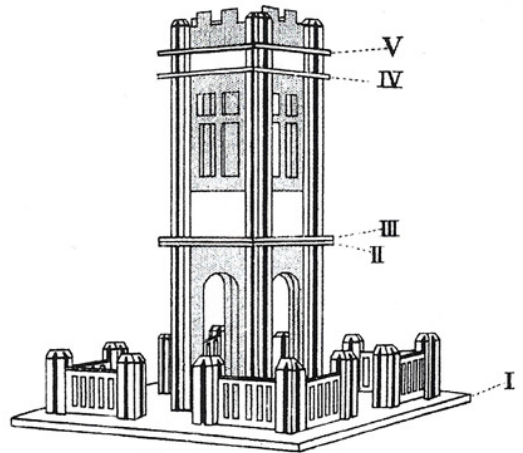

3

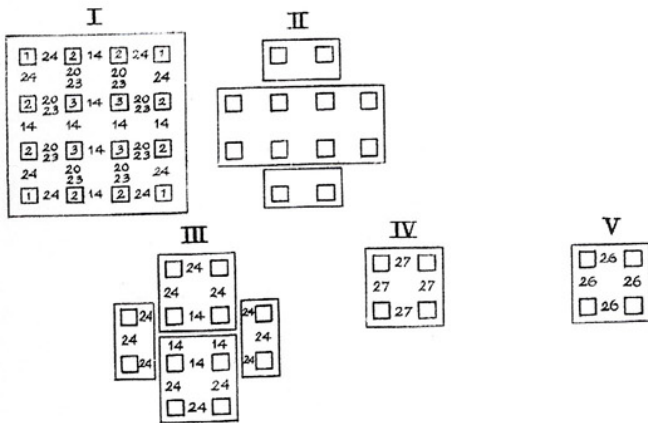
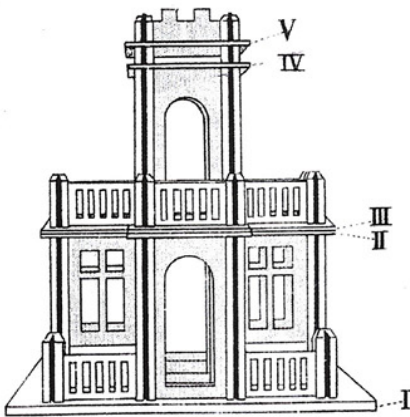

4

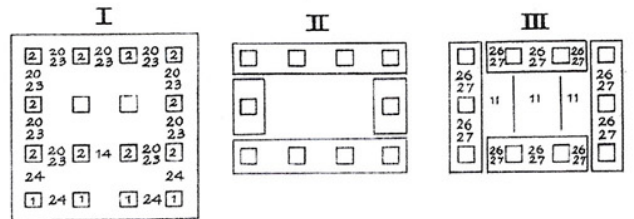
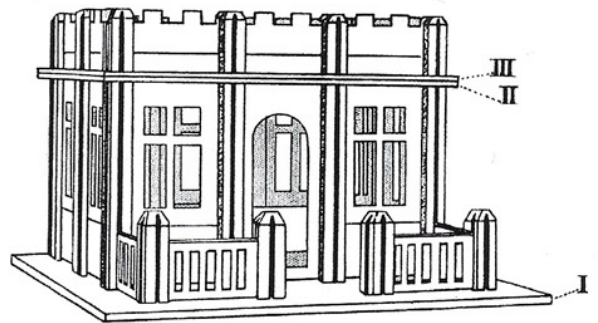

5

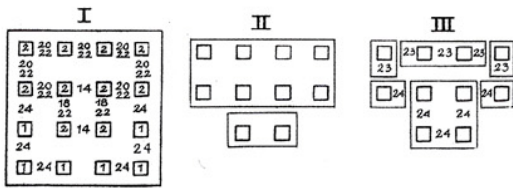
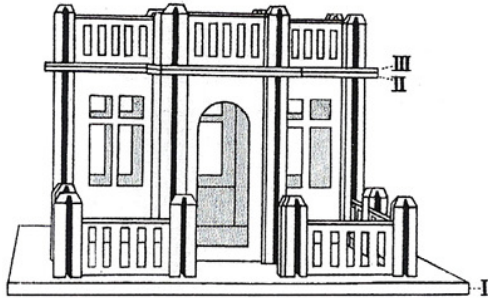

6

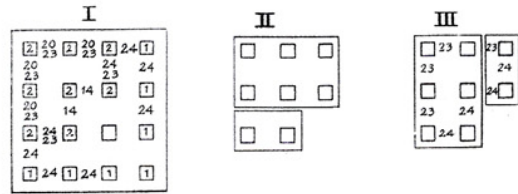
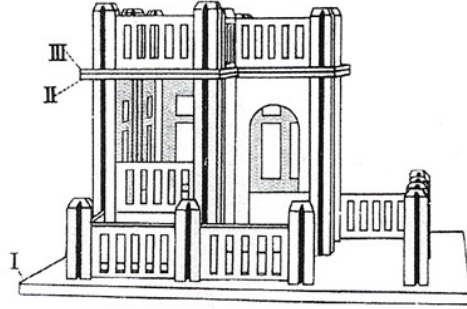

7

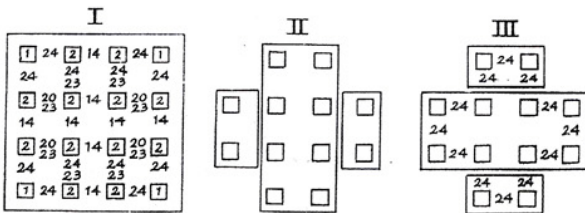
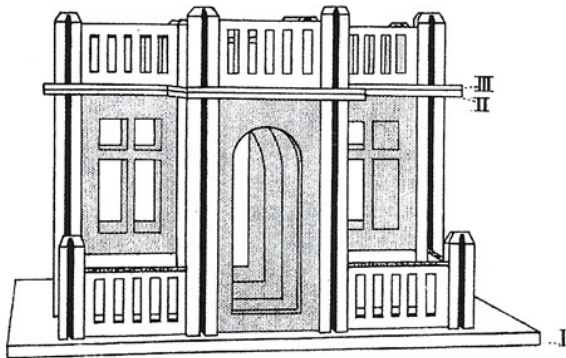

8

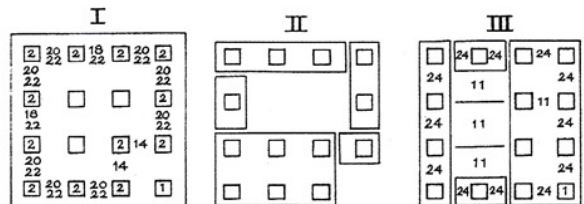
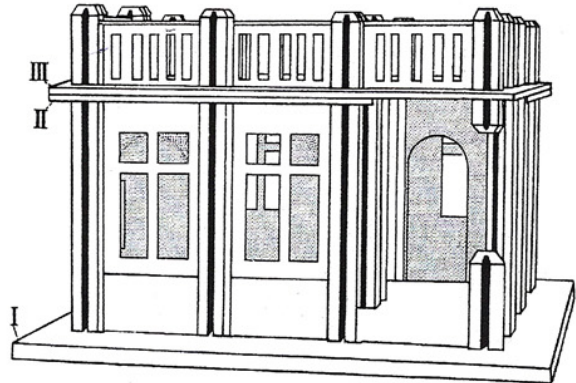

9

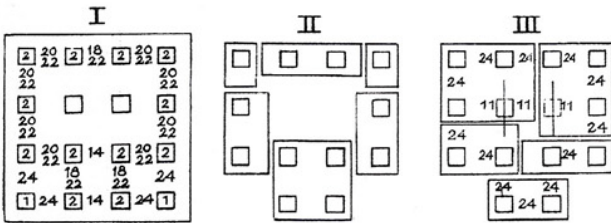
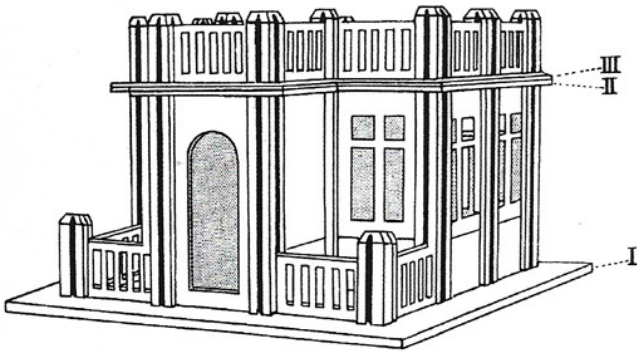

10

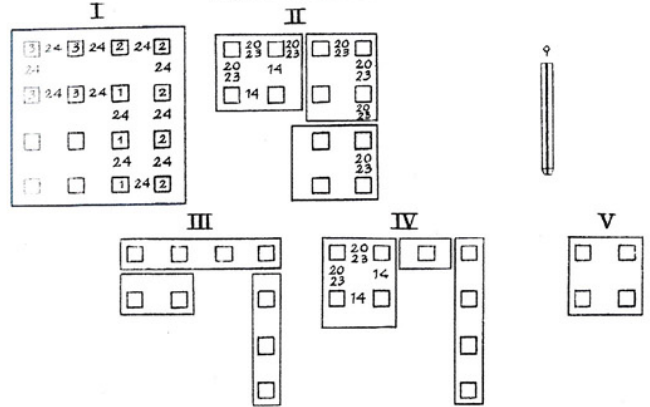
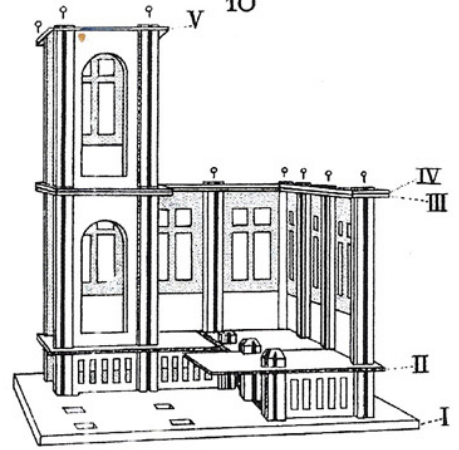

11

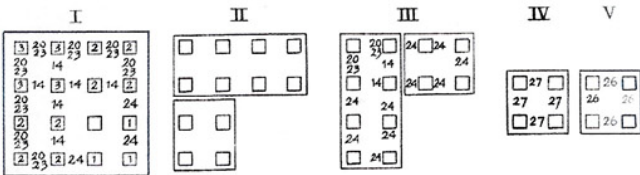
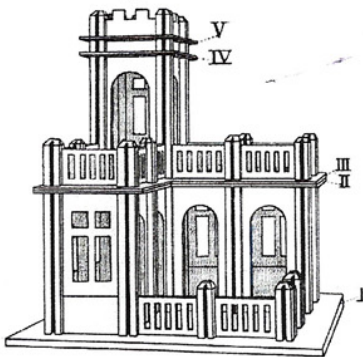

12

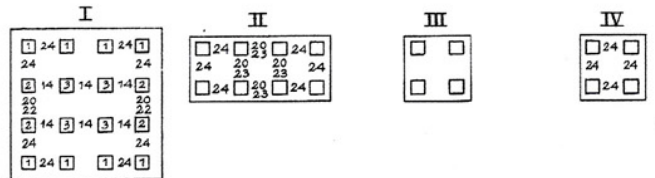
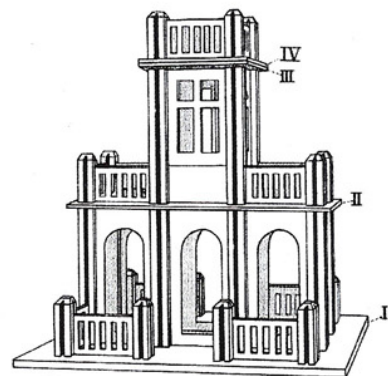



13

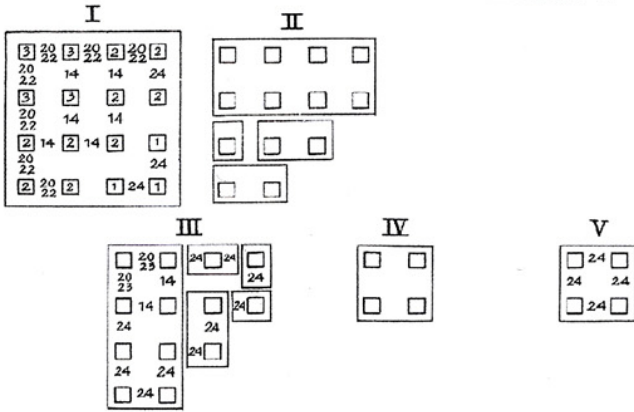
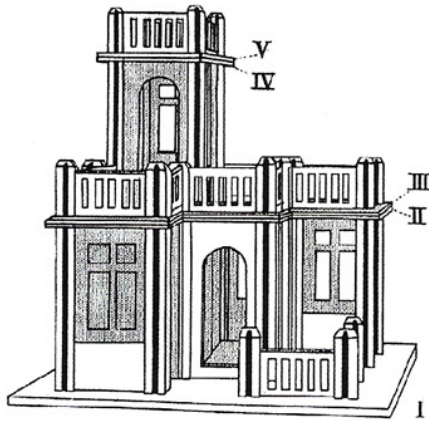

14

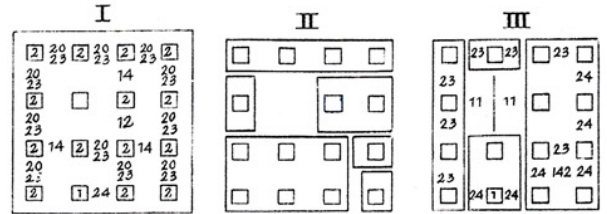
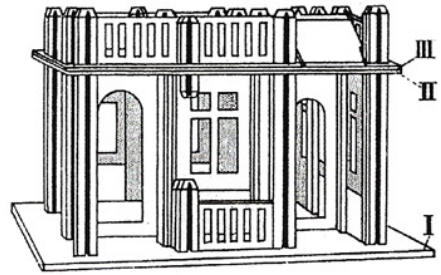

15

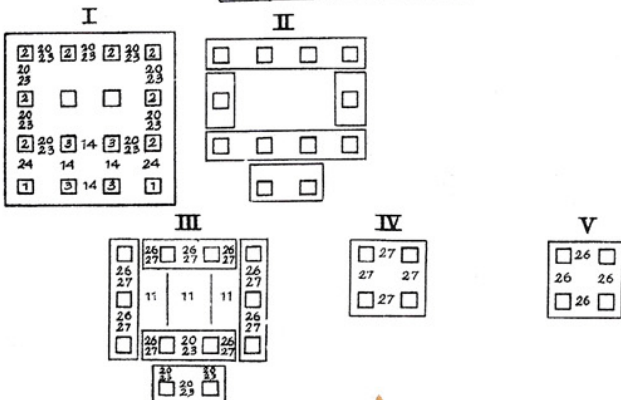
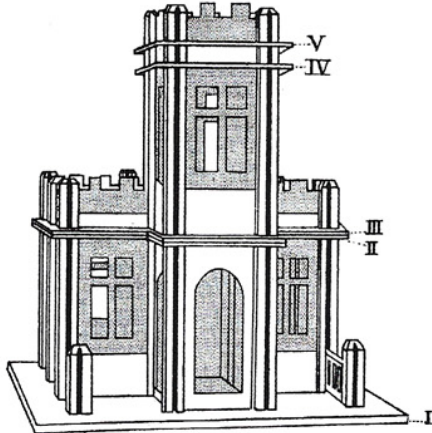

16

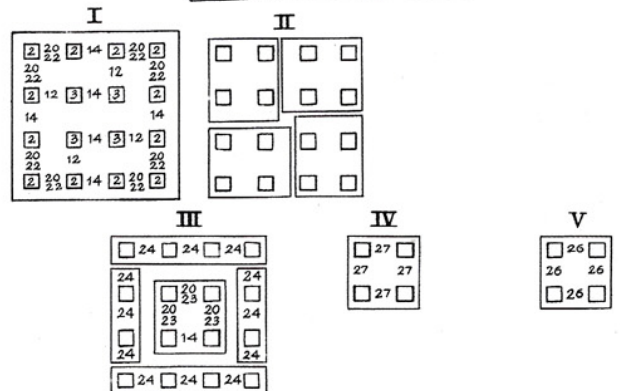
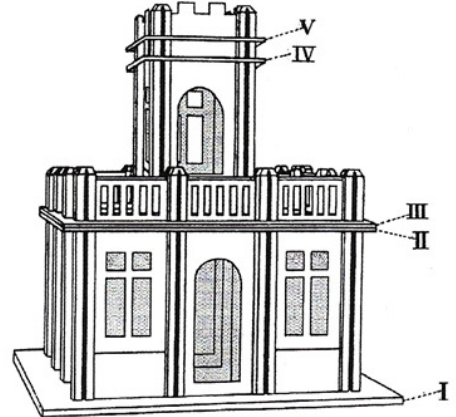

17

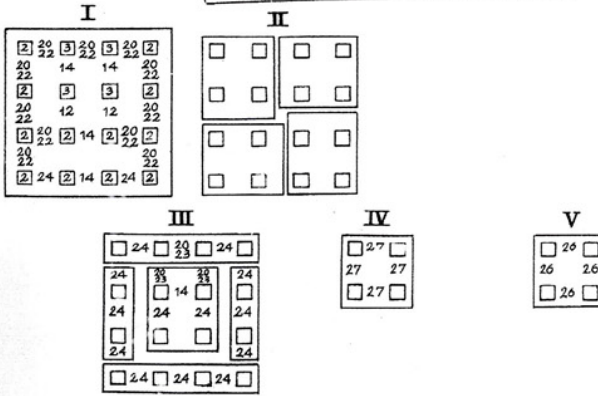
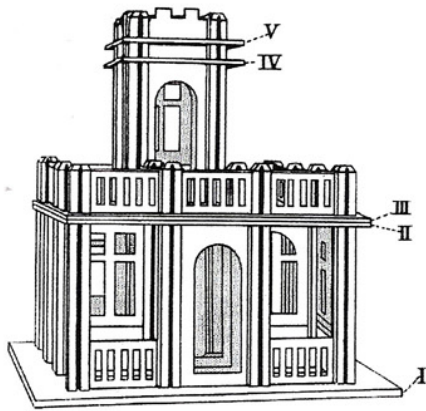

18

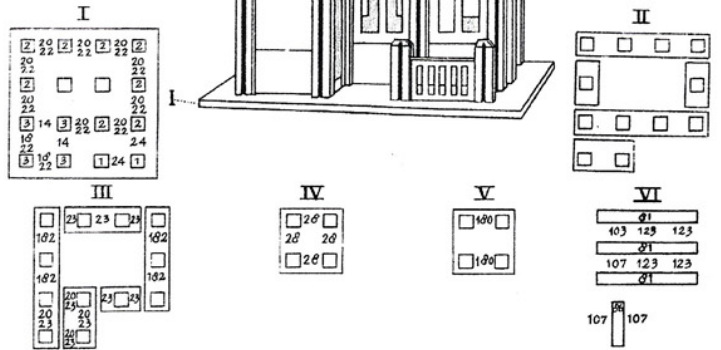
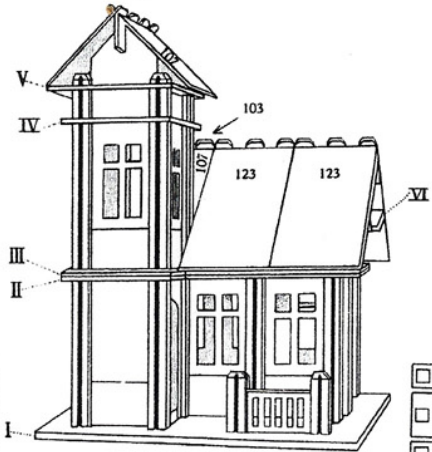

18

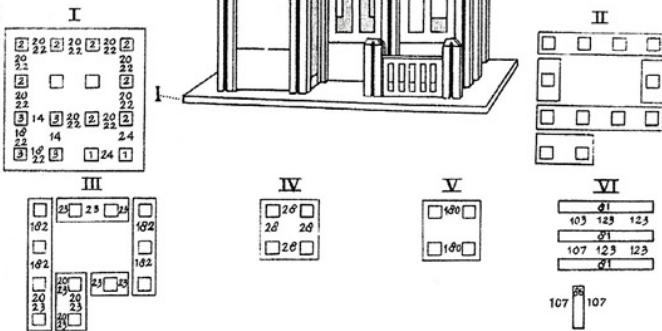
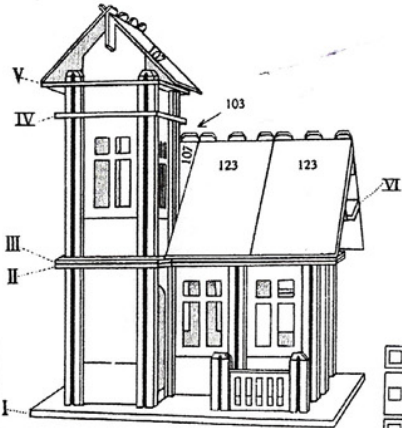

19

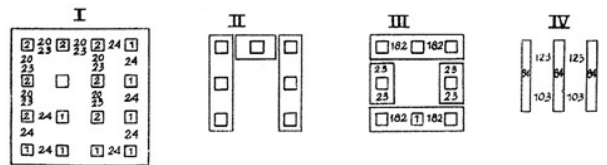
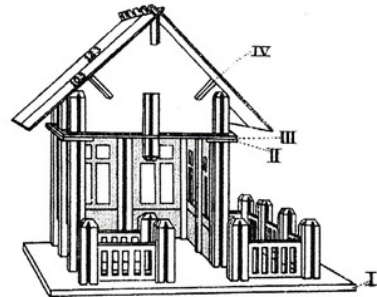

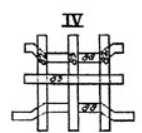
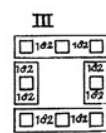
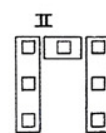
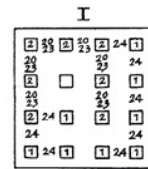
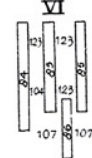
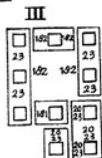
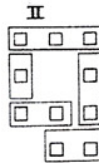
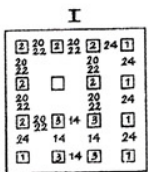
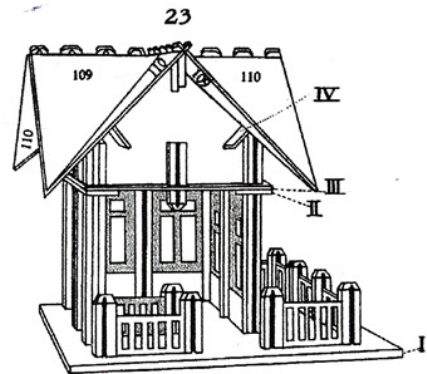
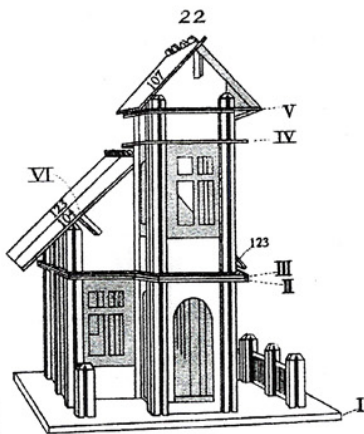
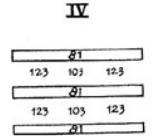
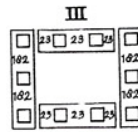
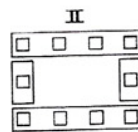
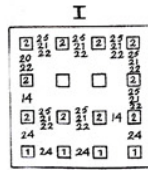
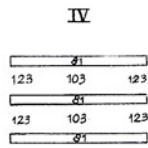
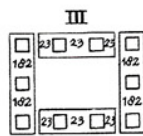
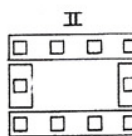
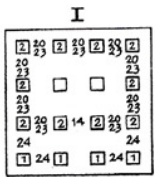
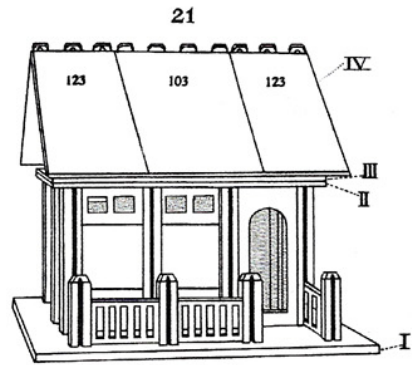
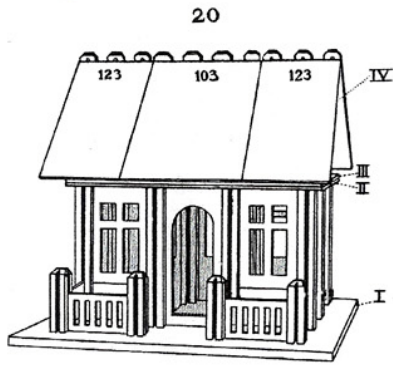

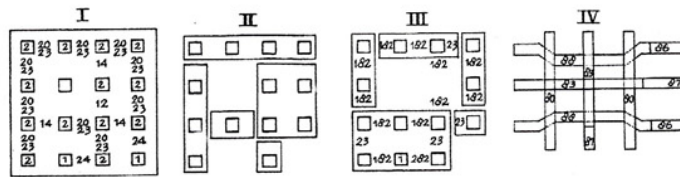
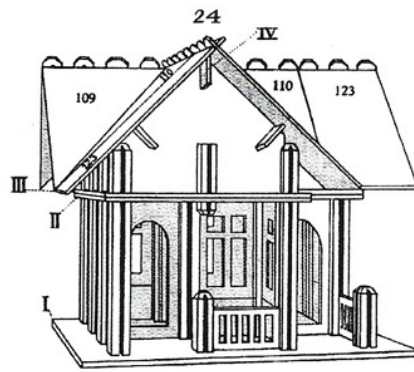

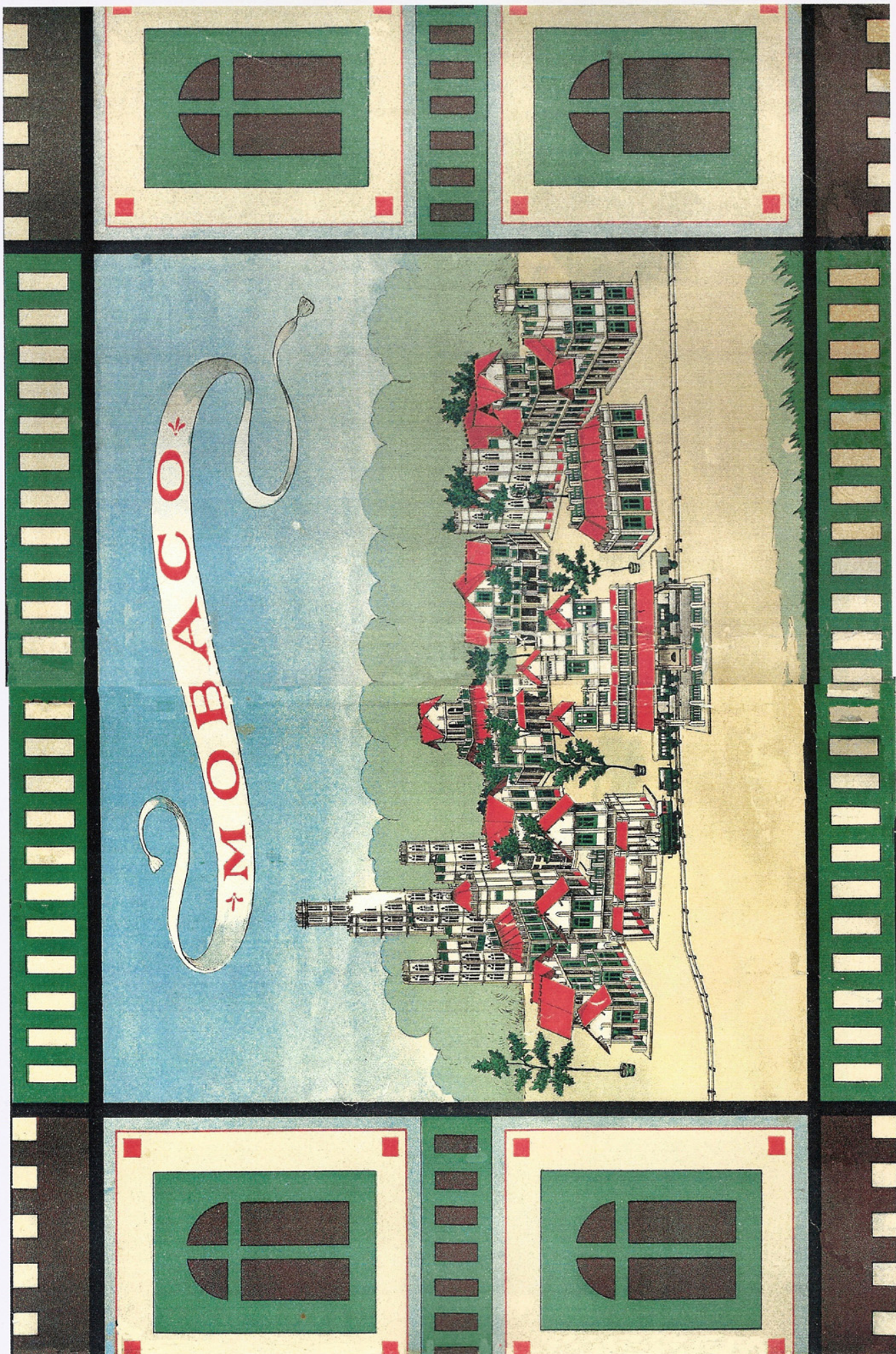

# VOORBEELDENBOEK 2

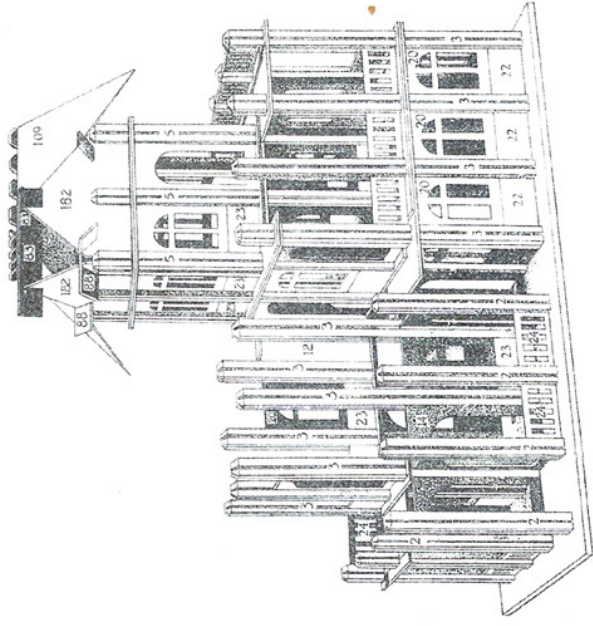
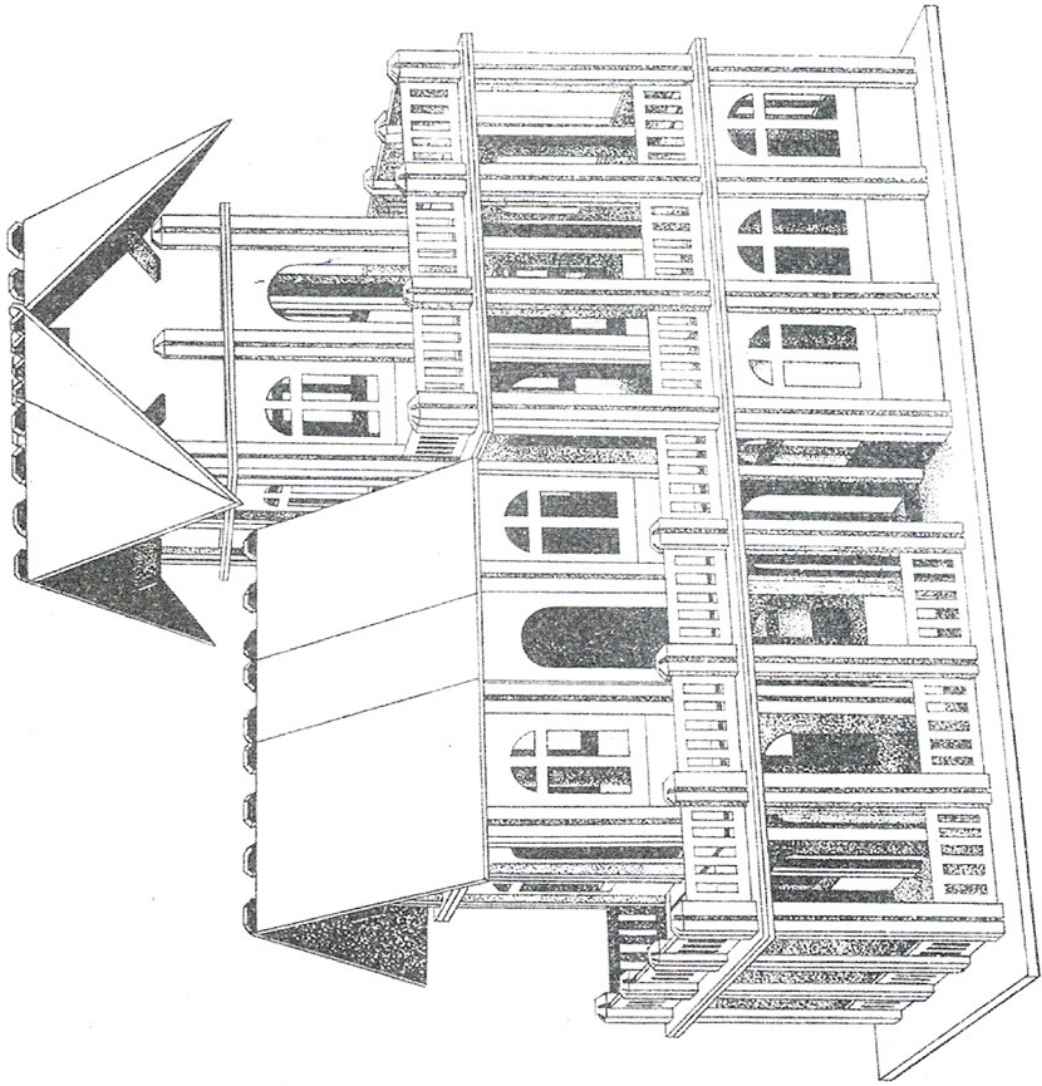

N° 1

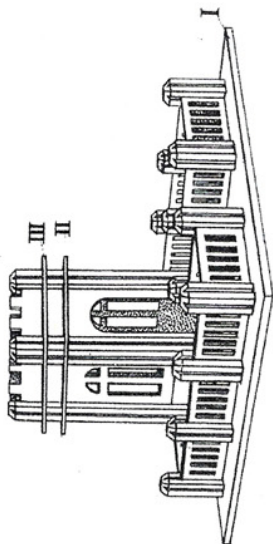

I

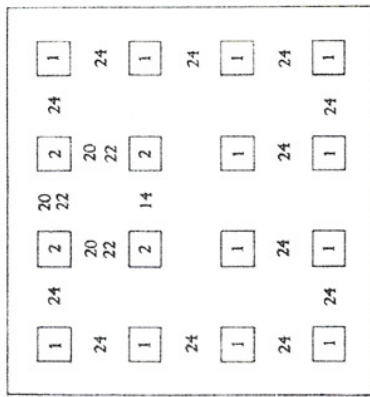

II

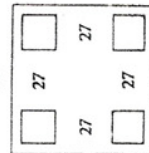

III

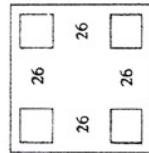

N° 2

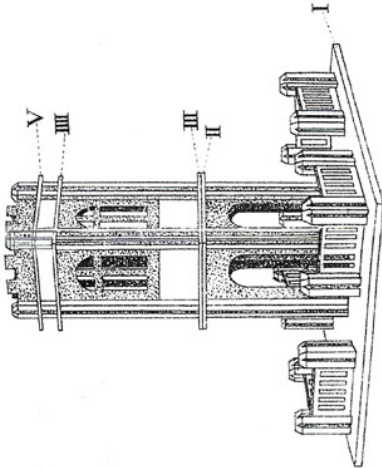

I

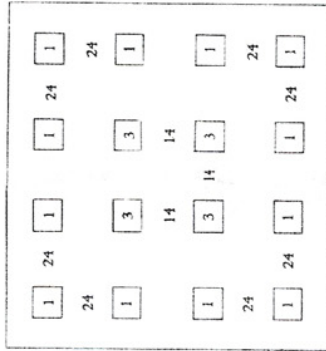

II

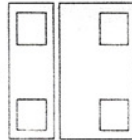

III

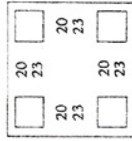

III

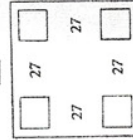

V

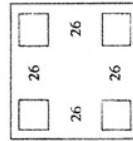

N° 3

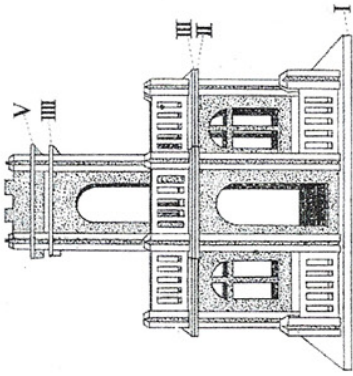

I

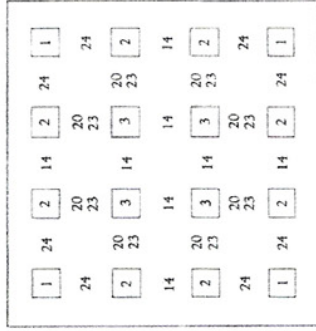

II

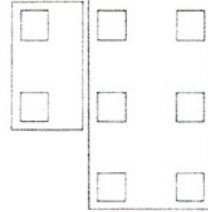

III

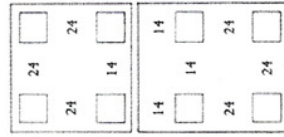

V

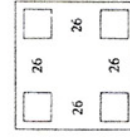

Nº 4

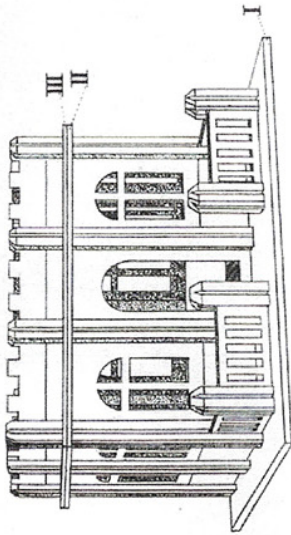

I

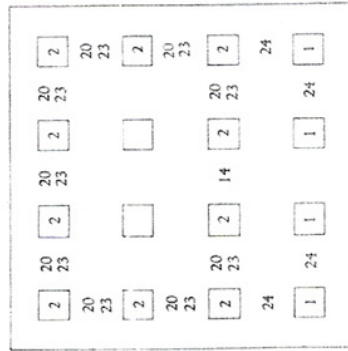

II

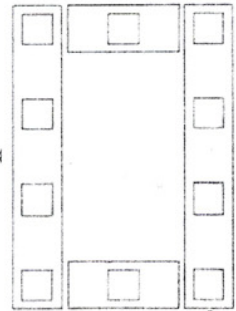

III

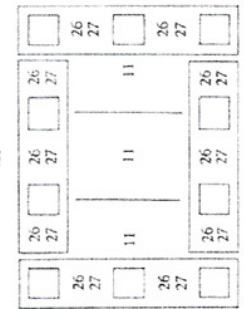

Nº 5

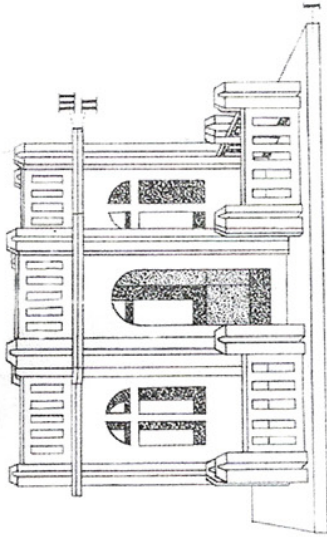

I

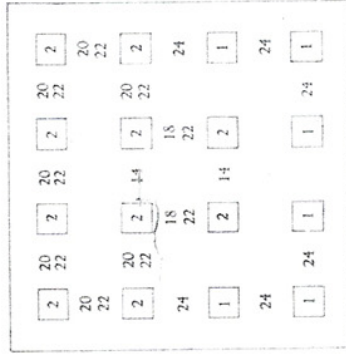

II

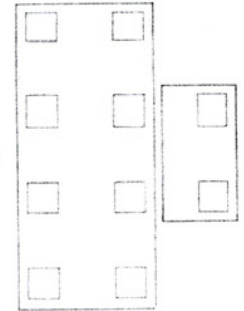

III

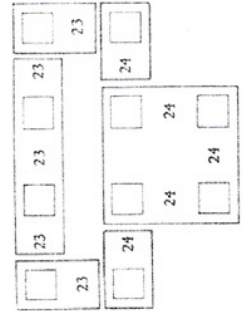

Nº 6

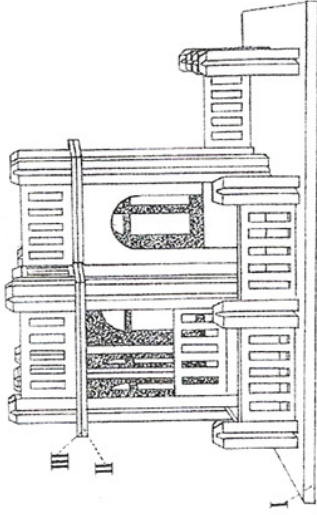

I



II

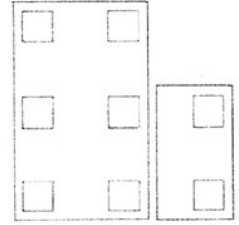

III

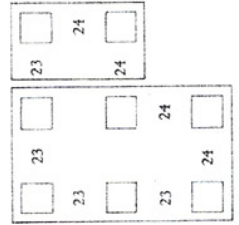



Nº 7

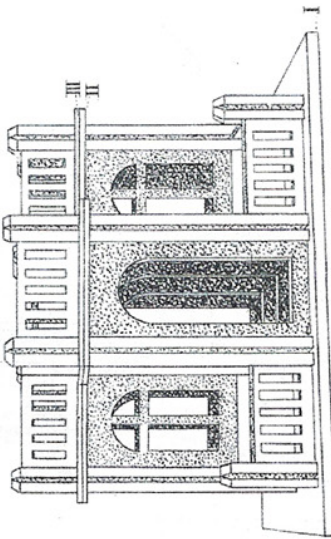

I



II

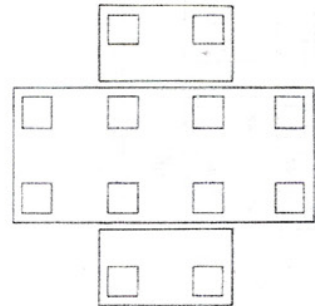

III

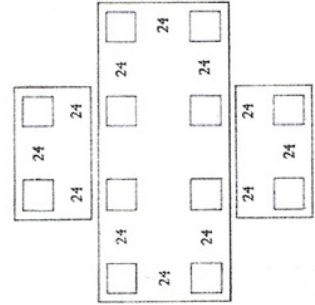

Nº 8

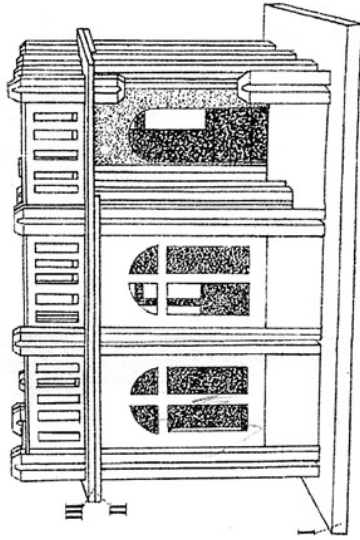

I

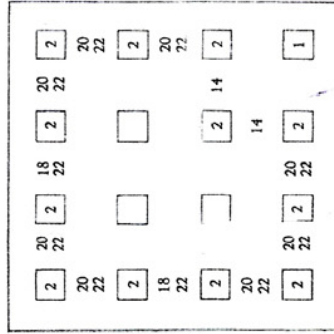

II

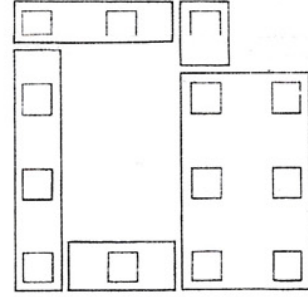

III

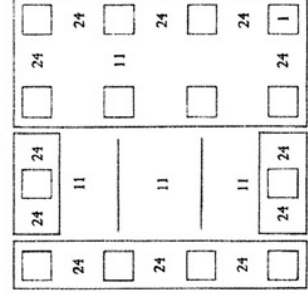

Nº 9

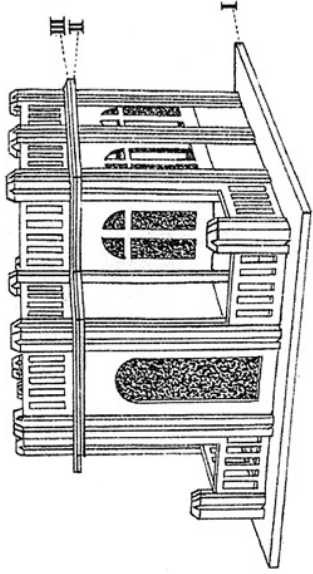

I

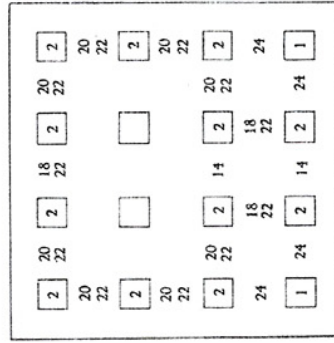

II

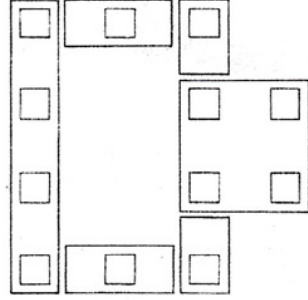

III

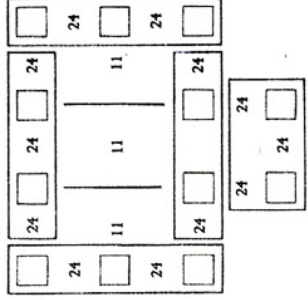

Nº 10

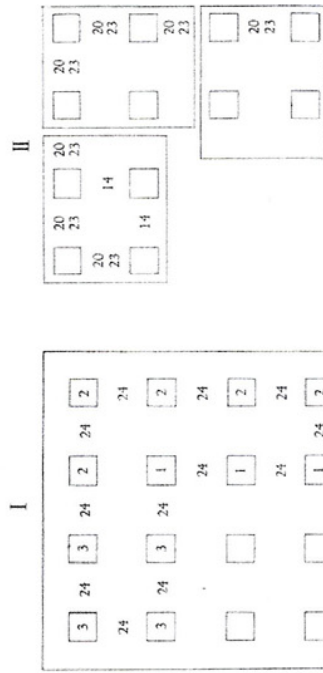
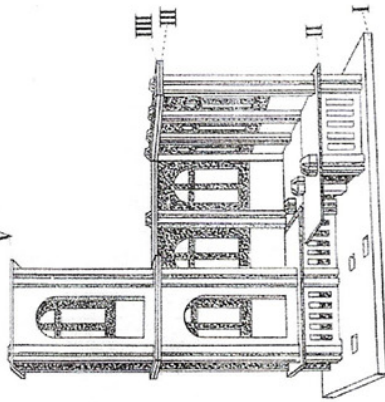

Nº 11

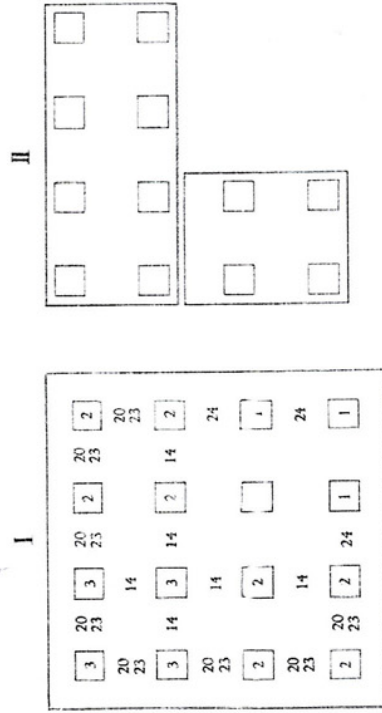
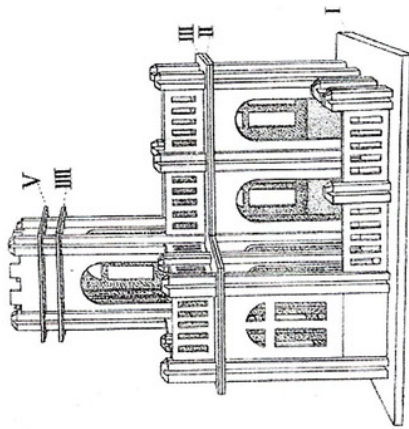

Nº 12

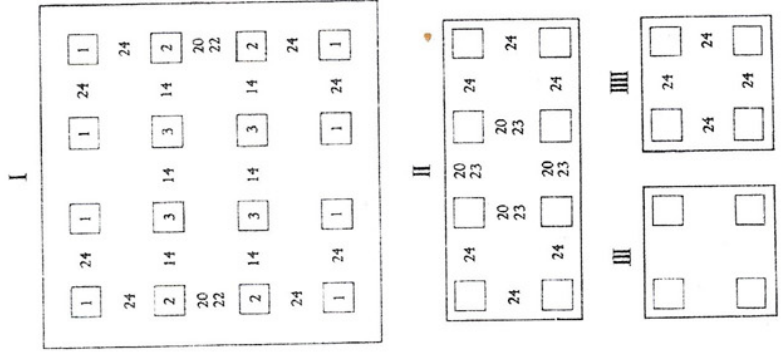
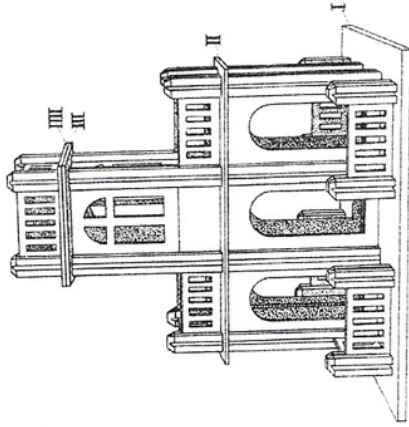

Nº 13

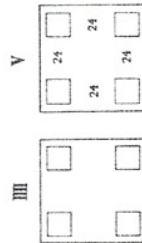
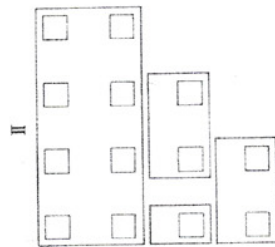
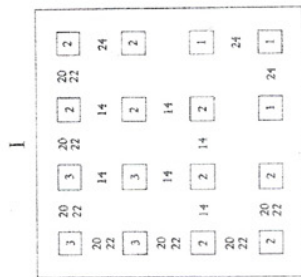
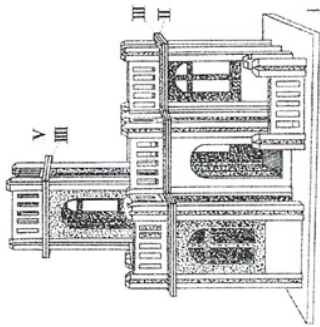

Nº 14

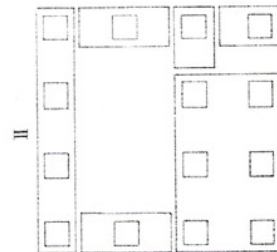
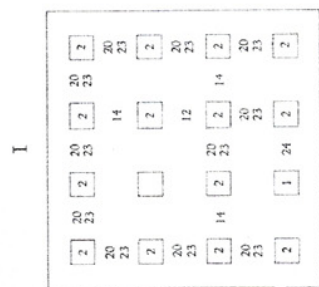
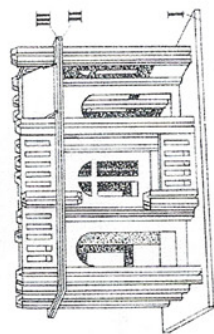

Nº 15

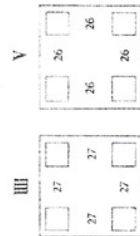
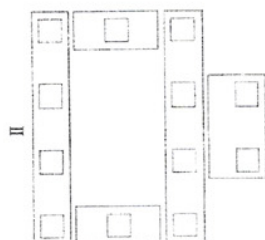
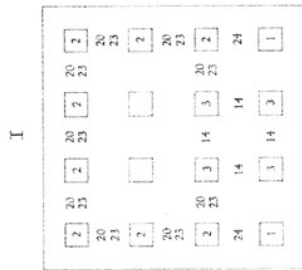
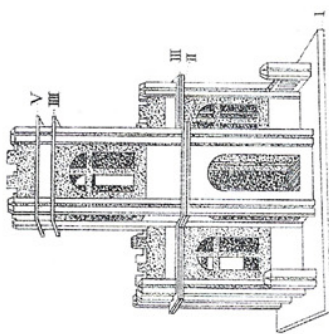



Nº19

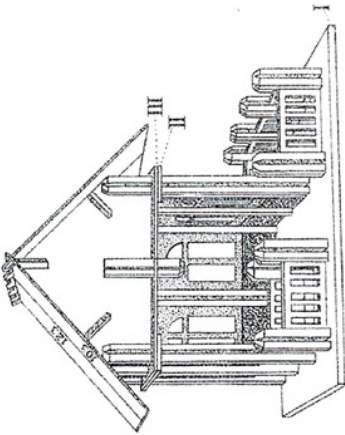

I



II

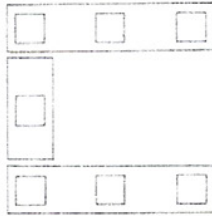

III

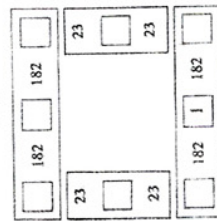

Nº20

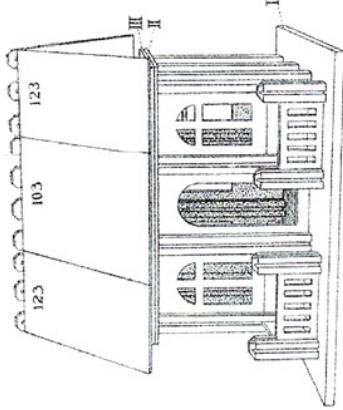

I

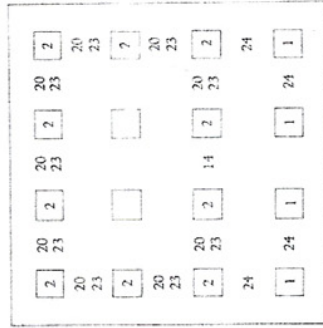

II

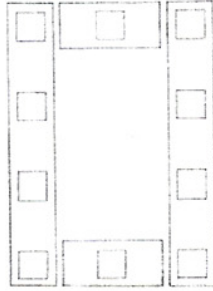

III

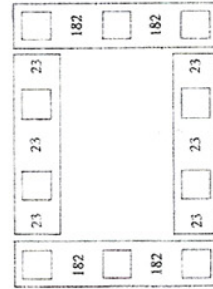

Nº21

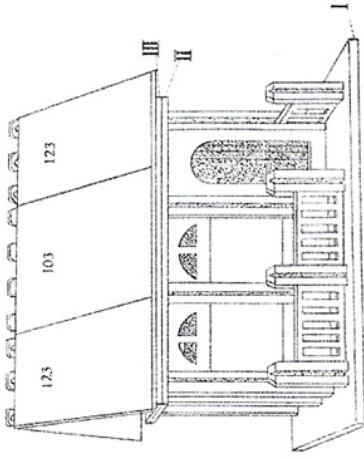

I



II

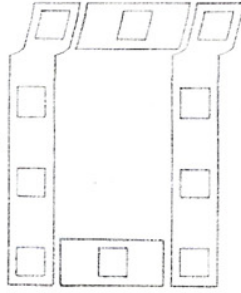

III

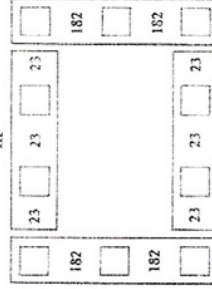

III



Nº 22

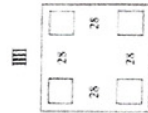
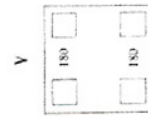
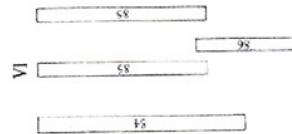
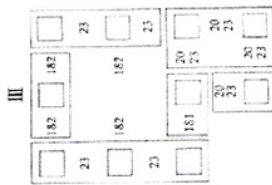
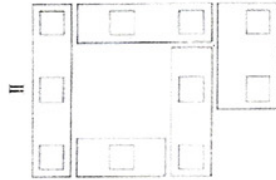
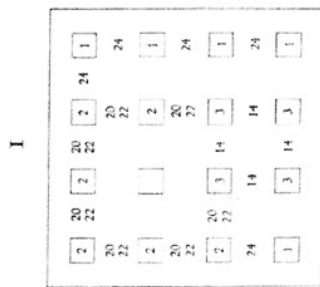
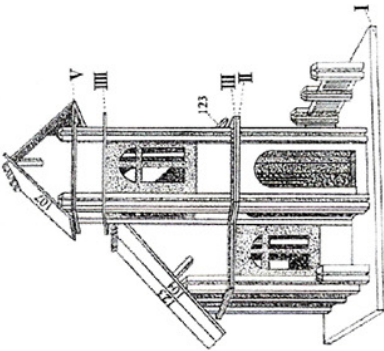

Nº 23

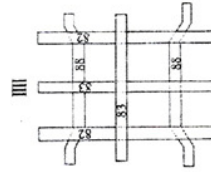
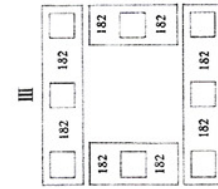
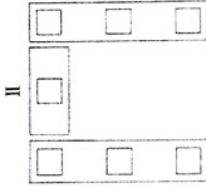
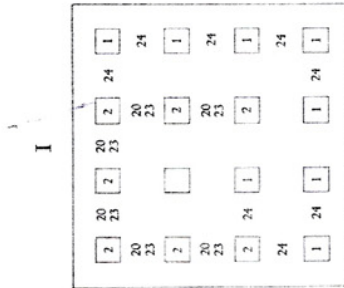
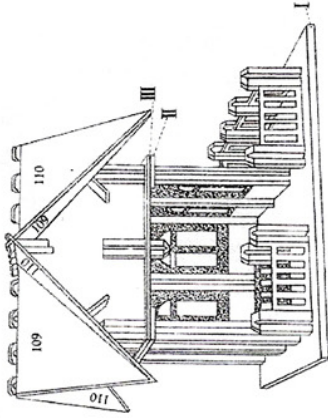

Nº 24

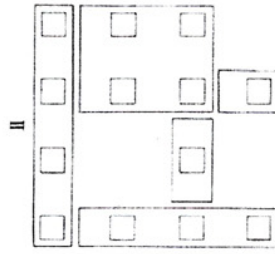
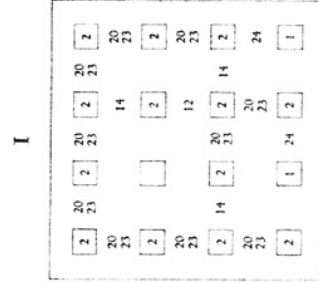
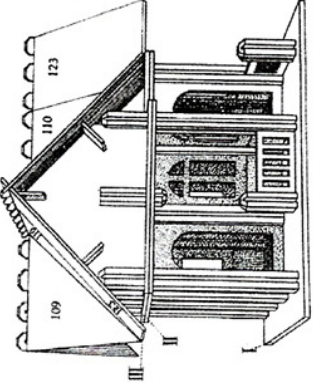









Nº 31

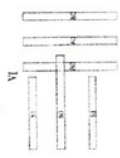
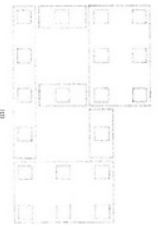
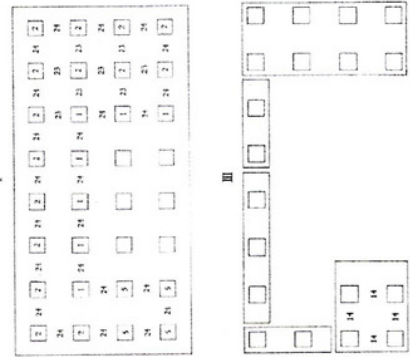
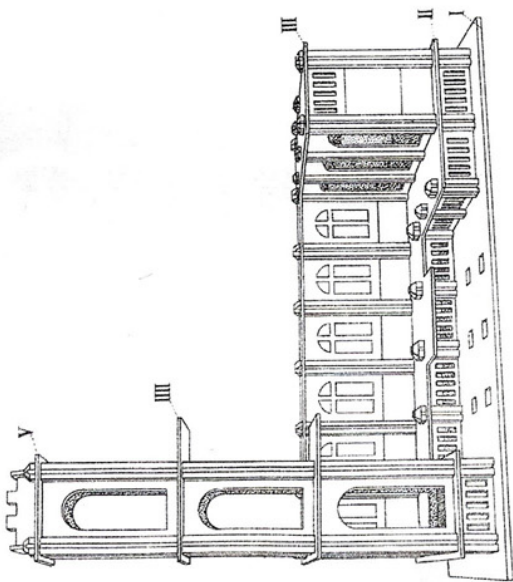

Nº 32

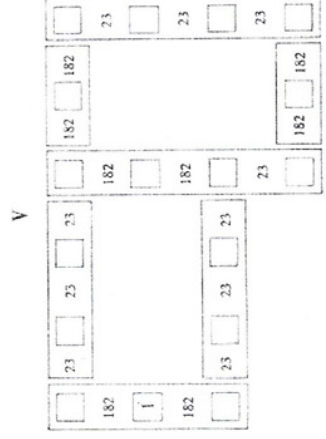
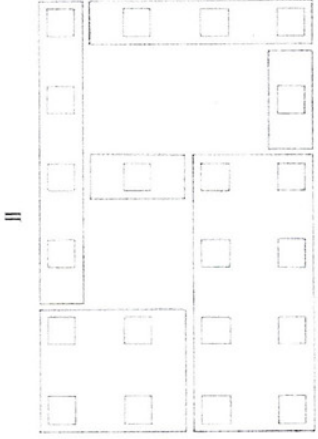
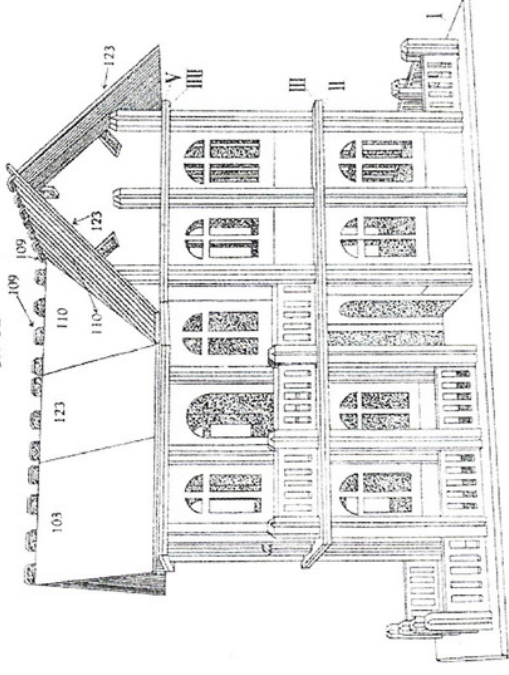

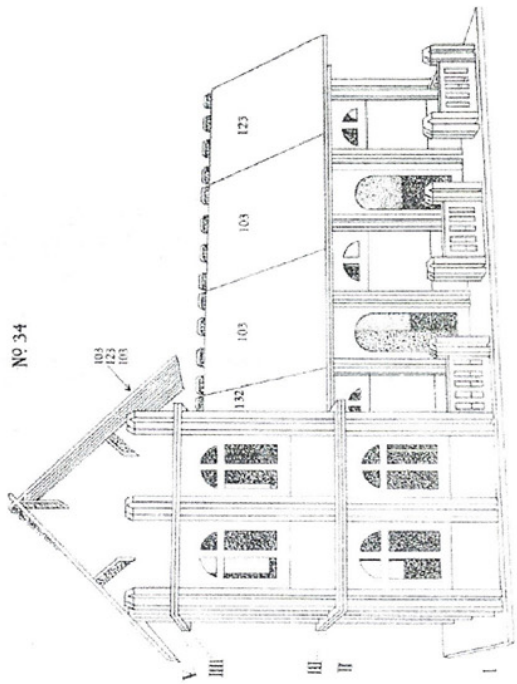

I

1	2	3	4	5	6	7	8	9	10	11	12	13	14	15	16	17	18	19	20	21	22	23	24	25	26	27	28	29	30	31	32	33	34	35	36	37	38	39	40	41	42	43	44	45	46	47	48	49	50	51	52	53	54	55	56	57	58	59	60	61	62	63	64	65	66	67	68	69	70	71	72	73	74	75	76	77	78	79	80	81	82	83	84	85	86	87	88	89	90	91	92	93	94	95	96	97	98	99	100
---	---	---	---	---	---	---	---	---	----	----	----	----	----	----	----	----	----	----	----	----	----	----	----	----	----	----	----	----	----	----	----	----	----	----	----	----	----	----	----	----	----	----	----	----	----	----	----	----	----	----	----	----	----	----	----	----	----	----	----	----	----	----	----	----	----	----	----	----	----	----	----	----	----	----	----	----	----	----	----	----	----	----	----	----	----	----	----	----	----	----	----	----	----	----	----	----	----	----	-----



III

1	2	3	4	5	6	7	8	9	10	11	12	13	14	15	16	17	18	19	20	21	22	23	24	25	26	27	28	29	30	31	32	33	34	35	36	37	38	39	40	41	42	43	44	45	46	47	48	49	50	51	52	53	54	55	56	57	58	59	60	61	62	63	64	65	66	67	68	69	70	71	72	73	74	75	76	77	78	79	80	81	82	83	84	85	86	87	88	89	90	91	92	93	94	95	96	97	98	99	100
---	---	---	---	---	---	---	---	---	----	----	----	----	----	----	----	----	----	----	----	----	----	----	----	----	----	----	----	----	----	----	----	----	----	----	----	----	----	----	----	----	----	----	----	----	----	----	----	----	----	----	----	----	----	----	----	----	----	----	----	----	----	----	----	----	----	----	----	----	----	----	----	----	----	----	----	----	----	----	----	----	----	----	----	----	----	----	----	----	----	----	----	----	----	----	----	----	----	----	-----



I

1	2	3	4	5	6	7	8	9	10	11	12	13	14	15	16	17	18	19	20	21	22	23	24	25	26	27	28	29	30	31	32	33	34	35	36	37	38	39	40	41	42	43	44	45	46	47	48	49	50	51	52	53	54	55	56	57	58	59	60	61	62	63	64	65	66	67	68	69	70	71	72	73	74	75	76	77	78	79	80	81	82	83	84	85	86	87	88	89	90	91	92	93	94	95	96	97	98	99	100
---	---	---	---	---	---	---	---	---	----	----	----	----	----	----	----	----	----	----	----	----	----	----	----	----	----	----	----	----	----	----	----	----	----	----	----	----	----	----	----	----	----	----	----	----	----	----	----	----	----	----	----	----	----	----	----	----	----	----	----	----	----	----	----	----	----	----	----	----	----	----	----	----	----	----	----	----	----	----	----	----	----	----	----	----	----	----	----	----	----	----	----	----	----	----	----	----	----	----	-----

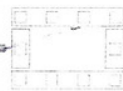

III

1	2	3	4	5	6	7	8	9	10	11	12	13	14	15	16	17	18	19	20	21	22	23	24	25	26	27	28	29	30	31	32	33	34	35	36	37	38	39	40	41	42	43	44	45	46	47	48	49	50	51	52	53	54	55	56	57	58	59	60	61	62	63	64	65	66	67	68	69	70	71	72	73	74	75	76	77	78	79	80	81	82	83	84	85	86	87	88	89	90	91	92	93	94	95	96	97	98	99	100
---	---	---	---	---	---	---	---	---	----	----	----	----	----	----	----	----	----	----	----	----	----	----	----	----	----	----	----	----	----	----	----	----	----	----	----	----	----	----	----	----	----	----	----	----	----	----	----	----	----	----	----	----	----	----	----	----	----	----	----	----	----	----	----	----	----	----	----	----	----	----	----	----	----	----	----	----	----	----	----	----	----	----	----	----	----	----	----	----	----	----	----	----	----	----	----	----	----	----	-----

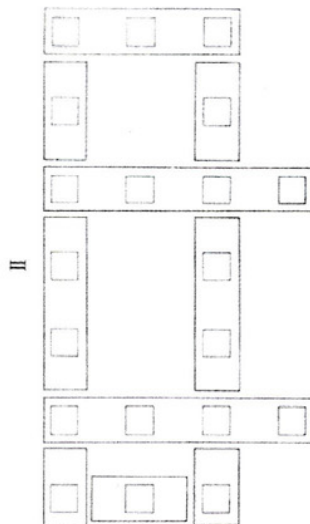
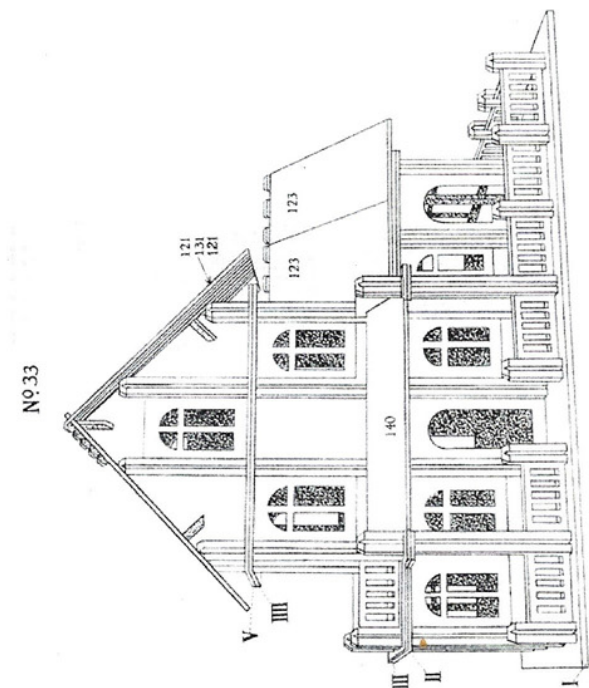
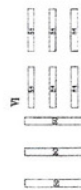

V

1	2	3	4	5	6	7	8	9	10	11	12	13	14	15	16	17	18	19	20	21	22	23	24	25	26	27	28	29	30	31	32	33	34	35	36	37	38	39	40	41	42	43	44	45	46	47	48	49	50	51	52	53	54	55	56	57	58	59	60	61	62	63	64	65	66	67	68	69	70	71	72	73	74	75	76	77	78	79	80	81	82	83	84	85	86	87	88	89	90	91	92	93	94	95	96	97	98	99	100
---	---	---	---	---	---	---	---	---	----	----	----	----	----	----	----	----	----	----	----	----	----	----	----	----	----	----	----	----	----	----	----	----	----	----	----	----	----	----	----	----	----	----	----	----	----	----	----	----	----	----	----	----	----	----	----	----	----	----	----	----	----	----	----	----	----	----	----	----	----	----	----	----	----	----	----	----	----	----	----	----	----	----	----	----	----	----	----	----	----	----	----	----	----	----	----	----	----	----	-----

Nº 35

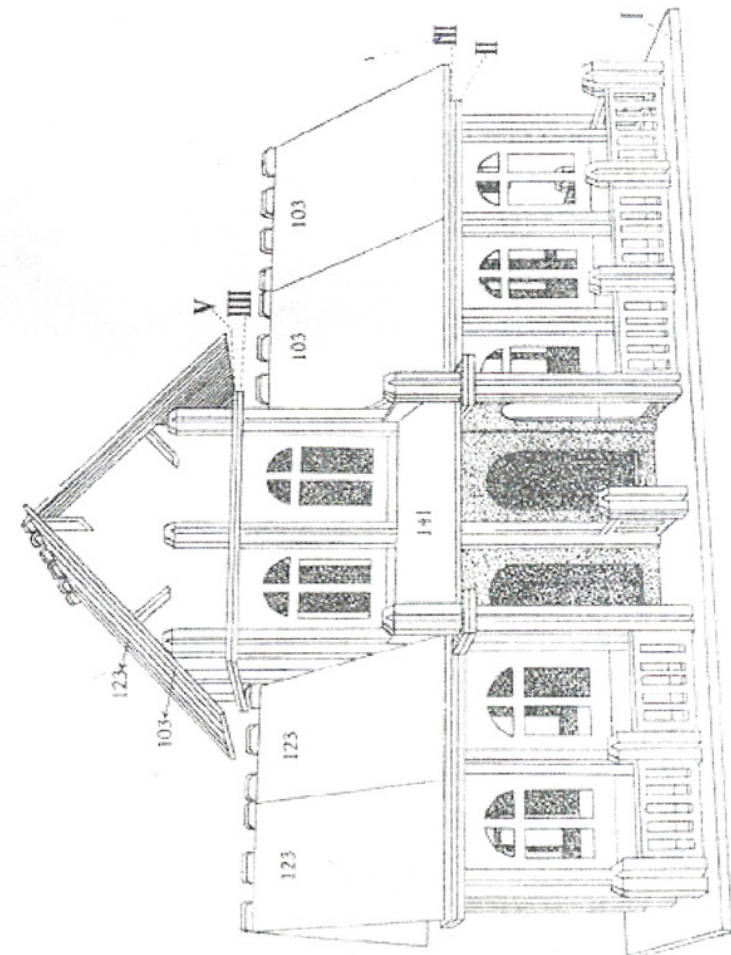

Nº 36

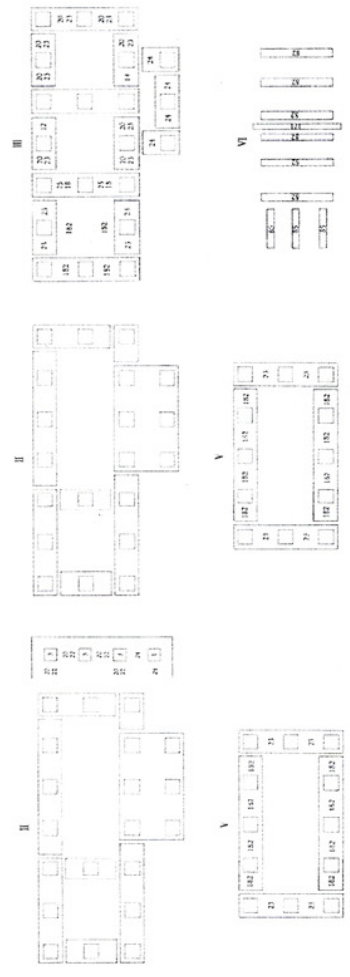
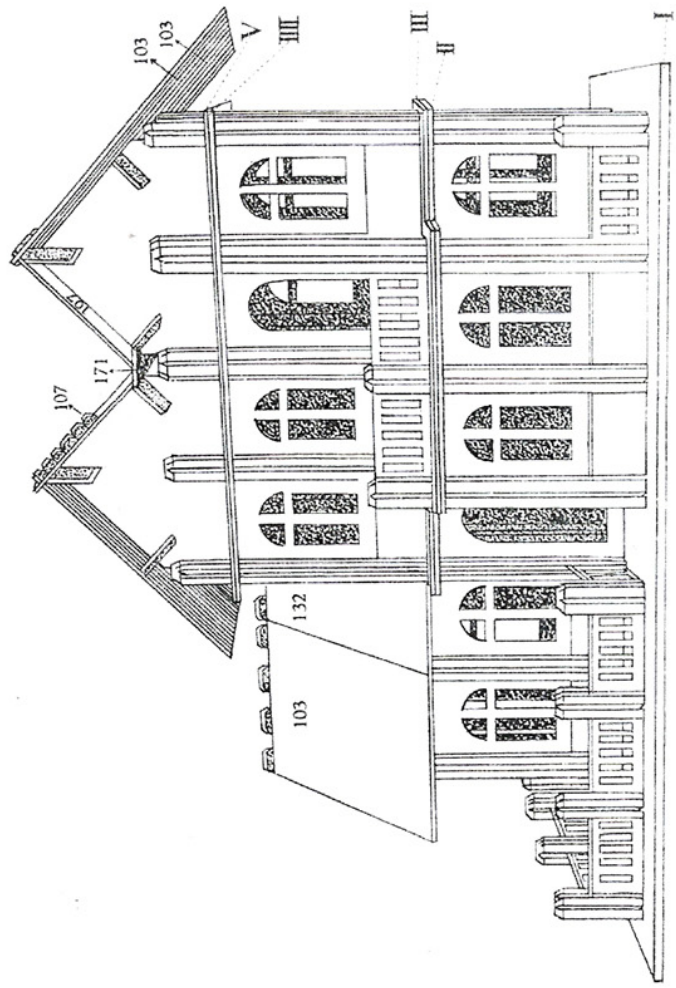

Nº 37

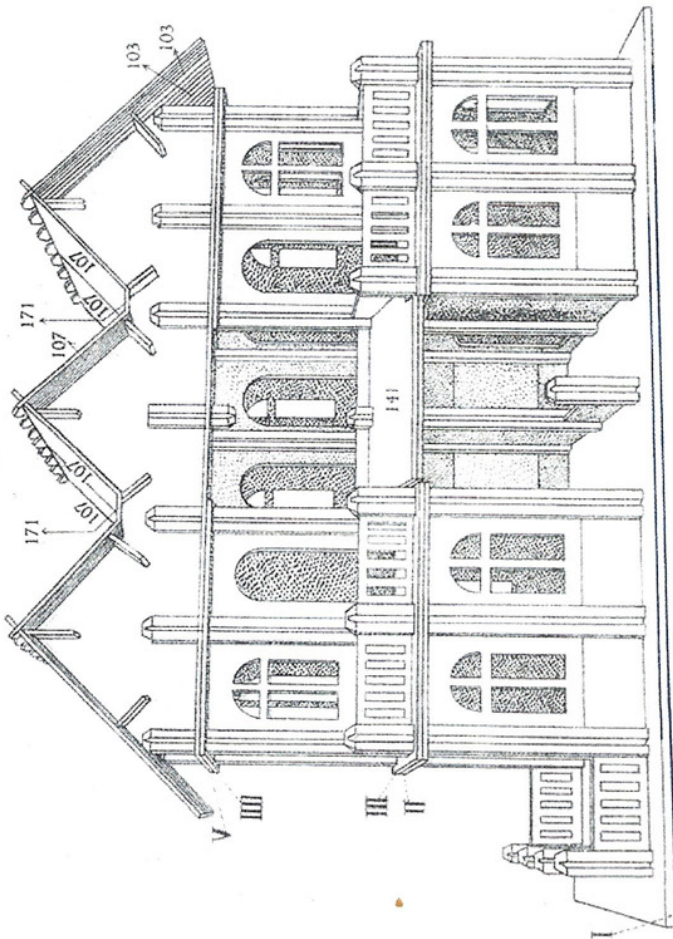

Nº 38

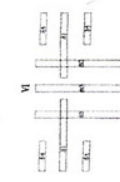
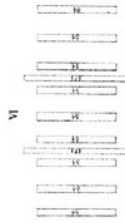
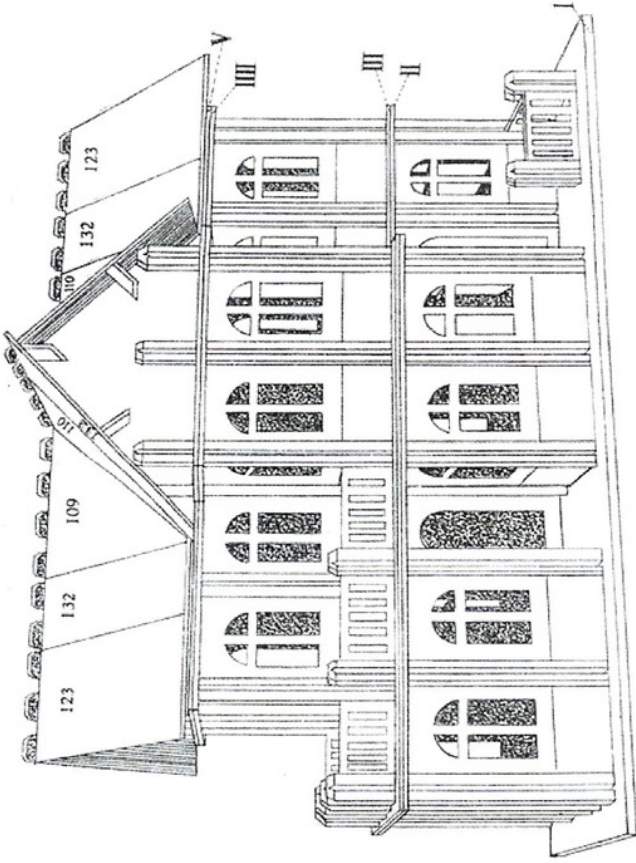

№ 39

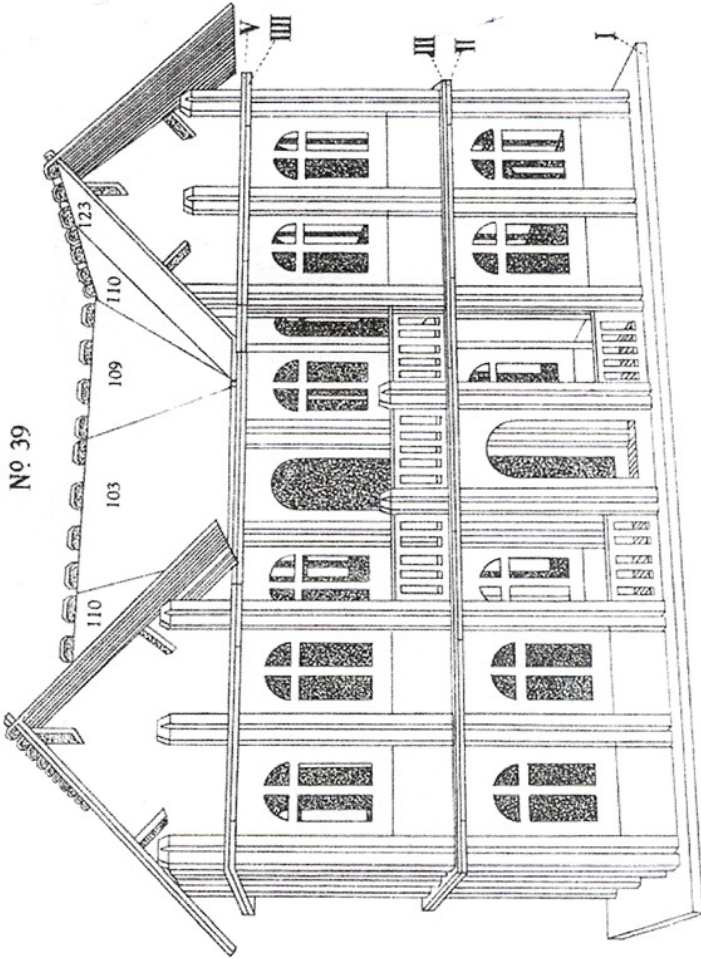

№ 40

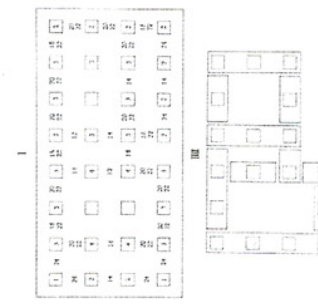
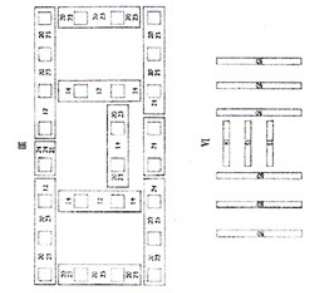
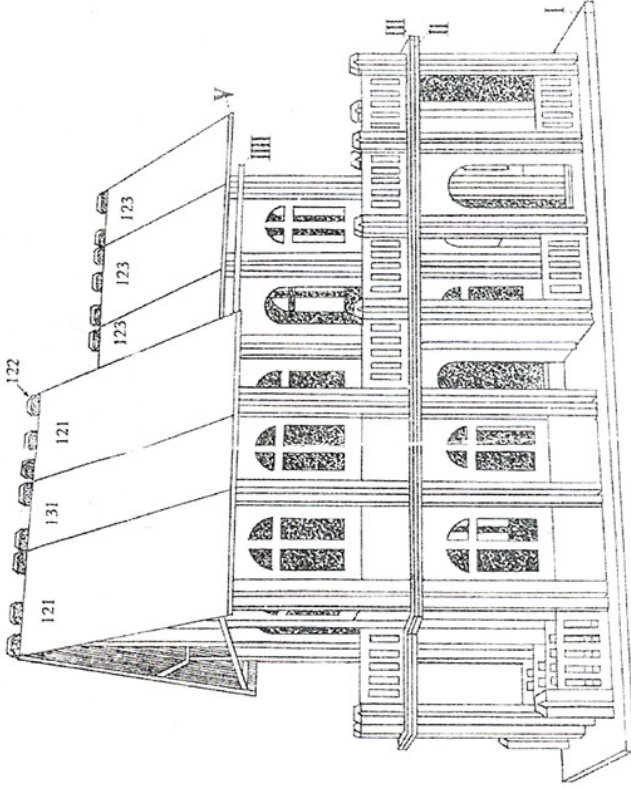



A-E

## MOBACO

As you will see in this book, the number of models you can build with MOBACO is unlimited. When you have tried all the models illustrated, you will still be able to construct many other houses, farms, churches, etc. according to your own ideas.

How to build such a model?

Well, that's not difficult. In the margin the illustrations show you how to do it. You always start with the floor; after that the piles are placed into the right holes, between which the walls and windows slide easily.

There are five different MOBACO standard outfits, namely A, B, C, D and E.

Each of these sets can be converted into the next succeeding size by means of the MOBACO complementary outfits A-B, B-C, C-D and D-E, e.g. the combination of sets A and A-B equal set B; combining of B and B-C equal set C, etc.

The larger the box you use, the greater of course is the number and variety of parts to build with; the more sets you buy, the more intricate and beautiful models you can build.

On the back of this book you will find a list and illustration of the various parts the MOBACO outfits contain.

¿Quieres ver lo más reciente y avanzado en Juegos?

¡Fíjate en el MOBACO!  
MOBACO te ofrece una variedad interminable de Construcciones de Pueblos y Ciudades

¿Cómo vamos a construir los modelos? No es difícil

Vamos a ver algunos ejemplos.  
¡Mira cómo la casa „MOBACO“ se va construyendo poco a poco entre tus manos! Empecemos por colocar la tabla del fundamento, después ponemos los postes en las distancias indicadas, dónde van a alzarse los muros, etc.

Con las piezas de las 5 cajas diferentes „MOBACO“, A, B, C, D, E, se puede construir todo lo que se quiera.

Cada uno de estos juegos puede convertirse en el tamaño sucesivo mediante las cajas suplementarias de MOBACO A-B, B-C, C-D y D-E. Por ejemplo, A más A-B es igual al juego B; una combinación de B y B-C es igual al juego C, etc.

El material „MOBACO“ es indestructible.

Cuanto más grande sea la caja, tanto mayor son las posibilidades.

Véase en la última página el pueblo con iglesia, ayuntamiento, puentes y casas, todo construido con „MOBACO“.

Para Construir una Ciudad, se necesitan diferentes cajas.

¡Pídeselas a tus amigos, para construir la juntos!

¡Ahora pongámonos a trabajar! y en breve tú serás un arquitecto MOBACO entusiasta.

Véase en el dorso el índice de los accesorios de las diferentes cajas.

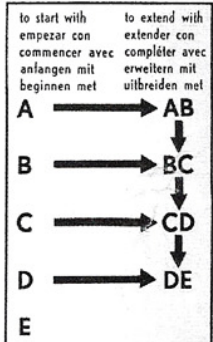
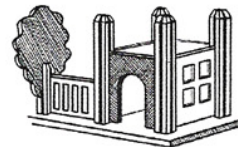
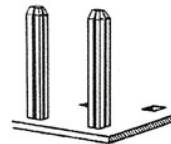

Ainsi que vous le voyez dans ce petit livre, le nombre de modèles que vous pouvez construire avec MOBACO est innombrable. Si vous avez construit tous les modèles indiqués dans ce petit livre, vous pourrez construire vous-même selon votre propre phantasie toutes sortes de bâtiments.

Comment construire un tel modèle? Eh bien, ce n'est pas si difficile. Les dessins à gauche vous font voir de quelle manière vous construisez une petite maison MOBACO. Vous commencez toujours par la plaque fondamentale, puis on place les piliers au bon endroit entre lesquels on glisse les murs, et c'est ainsi qu'on continue à construire.

Il y a cinq boîtes différentes, c.à.d. A, B, C, D, et E, chaque boîte suivante avec plus d'accessoires.

Chaque boîte peut être transformée en la boîte suivante au moyen des boîtes complémentaires A-B, B-C, C-D et D-E, p.e. la combinaison des boîtes A et A-B fait la boîte B; la boîte B avec B-C fait la boîte C, etc.

Plus la boîte est grande plus le nombre et la variété des accessoires sont grands.

Au verso de ce livre vous trouverez un aperçu qui vous montre quels accessoires se trouvent dans les différentes boîtes.

Wie Ihr in diesem Heft seht, könnt Ihr mit MOBACO zahllose Modelle zusammenstellen. Habt Ihr die ganzen Vorlagen aus diesem Heft erst mal nachgebaut, dann könnt Ihr nach eigener Phantasie neue Entwürfe bauen.

Das Bauen geht ganz einfach vor sich. Die Zeichnungen nebenan zeigen deutlich wie ein MOBACO Häuschen entsteht. Als Erstes kommt stets die Grundfläche, in deren Löcher die Holzpfähle in richtiger Entfernung gesteckt werden. Die Wände werden einfach dazwischen geschoben und die gelochten Platten halten dann den Bau ganz stabil zusammen. Das Dach schmückt das Ganze. Und so baut Ihr weiter, fidel und heiter!

Es gibt 5 MOBACO Grundbaukästen, nämlich A, B, C, D und E, und 4 Ergänzungskästen. Jeder Grundkasten kann durch den Zusatz eines Ergänzungskastens erweitert werden, z.B. Kasten A + A-B macht Kasten B; B + B-C macht C, u.s.w.

Auf der Rückseite dieses Heftes findet Du eine Tafel mit den verschiedenen MOBACO-Teilen die in den Kästen enthalten sind.

Die MOBACO-Teile sind aus unverwüstem Material hergestellt!

Zoals je in dit boekje zult zien, is het aantal modellen, dat je met MOBACO Dorpen- en Stedenbouw kunt bouwen, enorm. Heb je al de modellen uit dit boekje nagebouwd, dan kan je naar eigen fantasie zelf allerlei gebouwen ontwerpen en bouwen.

Hoe je zo'n model moet bouwen? Wel, dat is niet zo moeilijk. De tekeningen hiernaast laten je zien hoe een MOBACO huisje ontstaat. Je begint altijd met de grondplaat, daarna worden op de juiste afstand de paaltjes geplaatst, waartussen de muren worden opgetrokken en zo bouw je steeds verder.

Er zijn 5 verschillende MOBACO gronddozen, n.l. A, B, C, D en E, iedere volgende doos met meer onderdelen. Elke doos kan echter worden omgezet in de daaropvolgende, dus in een grotere doos, n.l. door het kopen van een aanvullingsdoos. Op deze wijze kan je doos A omzetten in doos B, door doos A-B te kopen.

Zo kan je dus, ongeacht met welke gronddoos je begint, je uitrusting langzamerhand uitbreiden, want begin je met doos D, dan kan je die door aanvullingsdoos D-E omzetten in gronddoos E. Volg de pijltjes van het schema.

Alle MOBACO onderdelen zijn uit onverwoestbaar materiaal vervaardigd.

Hoe groter de doos, des te groter het aantal en de verscheidenheid aan onderdelen. Hiermede kan je dus steeds mooier en ingewikkelder modellen maken.

Als het klaar is, kan je er nog je andere speelgoed, zoals auto's, treinen enz. bij halen. Dan ziet het er nog echter uit.

Maar nu aan de slag en spoedig zal jij ook tot de enthousiaste MOBACO architecten behoren! Op de achterzijde van dit boekje vind je een tabel waarop je kunt zien, welke onderdelen in de verschillende dozen zitten.

Alle onderdelen zijn ook los verkrijgbaar.

## MOBACO A

THESE MODELS CAN BE BUILT WITH OUTFIT A  
ESTOS MODELOS SE PUEDEN CONSTRUIR CON A  
CES MODELES PEUVENT ÊTRE CONSTRUITS AVEC LA BOÎTE A

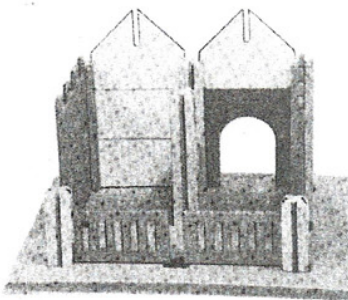

A 4

Paardenstal Stable Pferdestall	A 4 Écurie Caballeriza	Speelplaats Playground Spielplatz	A 3 Place de jeux Patio de Juegos
2 x No.	1	2 x No.	1
4 " "	1½	4 " "	1½
2 " "	23	2 " "	22
2 " "	24	2 " "	23
1 " "	54	2 " "	24
2 " "	107	1 " "	54
2 " "	180	1 " "	70
1 " "	201	1 " "	76
		1 " "	201

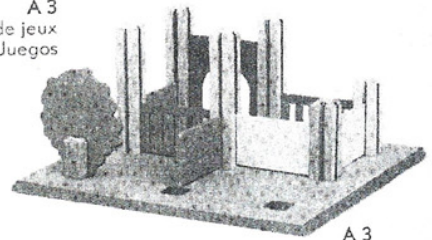

A 3

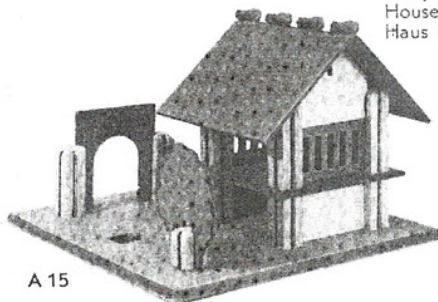

A 15

Huisje House Haus mit Tor	A 15 Maisonnette Casita	Buitenhuis Cottage Gärtnerhaus	A 7 Maison de Campagne Casita de Campo
2 x No.	1	2 x No.	1
4 " "	1½	4 " "	1½
2 " "	22	1 " "	19
2 " "	23	2 " "	22
2 " "	24	2 " "	23
1 " "	54	2 " "	24
1 " "	62	1 " "	54
1 " "	70	1 " "	62
1 " "	76	1 " "	70
2 " "	107	1 " "	76
2 " "	180	2 " "	107
1 " "	201	2 " "	180
		1 " "	201

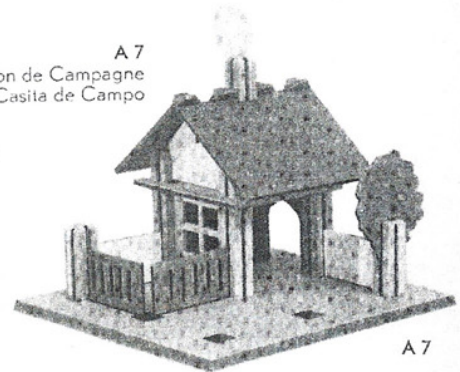

A 7



DIESE MODELLE KÖNNEN GEBAUT WERDEN MIT KASTEN A  
 DEZE MODELLEN KUNNEN GEBOUWD WORDEN MET DOOS A

**MOBACO**  
**A**

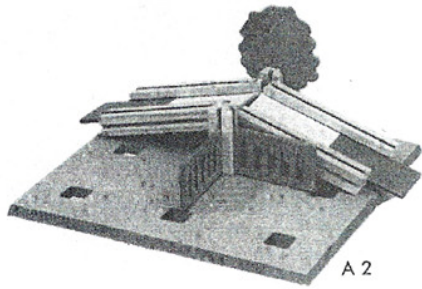

Bruggetje		A 2
Brücke	Petit pont	Puente
2 x No.	1	
4 " "	1 1/2	
2 " "	22	
2 " "	23	
2 " "	24	
1 " "	70	
1 " "	201	

A 2

Villaatje		A 9
Villa	Petite villa	Villa
2 x No.	1	
4 " "	1 1/2	
1 " "	19	
2 " "	22	
2 " "	23	
2 " "	24	
1 " "	54	
1 " "	62	
1 " "	70	
1 " "	76	
2 " "	107	
2 " "	180	
1 " "	201	

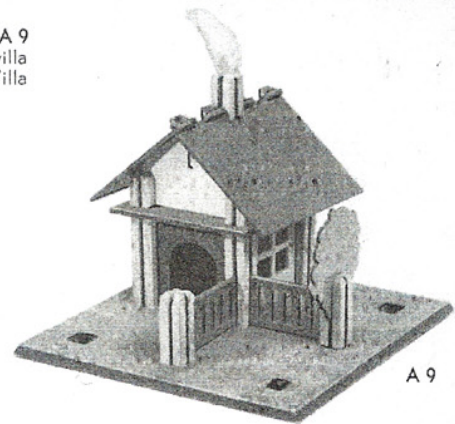

A 9

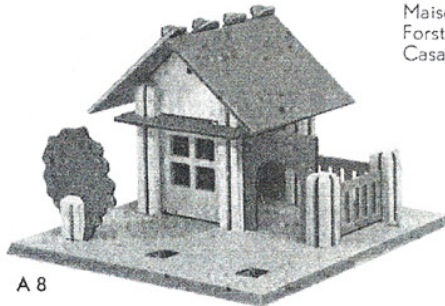

A 8

Boswachterswoning A 8  
 Gamekeeper's cottage  
 Maison du garde forestier  
 Forsthaus  
 Casa del Guardabosque

2 x No.	1
4 " "	1 1/2
1 " "	19
2 " "	22
2 " "	23
2 " "	24
1 " "	54
1 " "	62
1 " "	70
1 " "	76
2 " "	107
2 " "	180
1 " "	201

Kippenhok A 16  
 Hen-house  
 Poultry  
 Hühnerstall  
 Gallinero

2 x No.	1
4 " "	1 1/2
1 " "	19
2 " "	22
2 " "	23
2 " "	24
1 " "	54
1 " "	62
1 " "	70
1 " "	76
1 " "	201

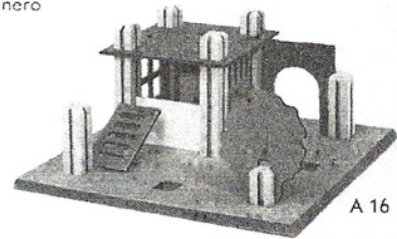

A 16

**MOBACO**  
**B**

THESE MODELS CAN BE BUILT WITH OUTFIT B OR A + AB  
 ESTOS MODELOS SE PUEDEN CONSTRUIR CON B O A + AB  
 CES MODÈLES PEUVENT ÊTRE CONSTRUITS AVEC LA BOÎTE B OU A + AB

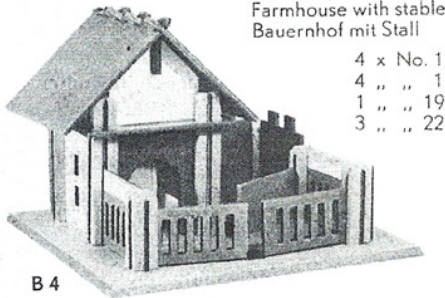

B 4

Boerderij met stal B 4  
 Farmhouse with stable  
 Bauernhof mit Stall

4 x No.	1	3 x No.	23
4 " "	1 1/2	4 " "	24
1 " "	19	2 " "	26
3 " "	22	3 " "	27
		1 " "	54
		1 " "	62
		1 " "	86
		2 " "	107
		2 " "	180
		1 " "	201

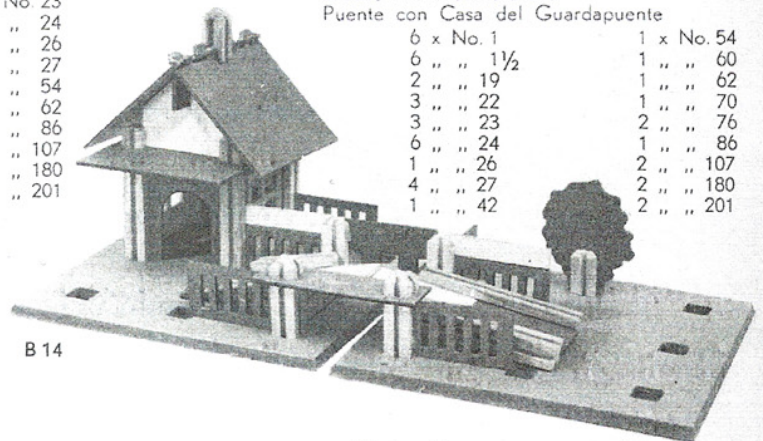

B 14

Brug met brugwachtershuis B 14  
 Bridge with bridgekeeper's house  
 Pont avec maison de pontier  
 Brücke mit Wächtershaus  
 Puente con Casa del Guardapunte

6 x No.	1	1 x No.	54
6 " "	1 1/2	1 " "	60
2 " "	19	1 " "	62
3 " "	22	1 " "	70
3 " "	23	2 " "	76
6 " "	24	1 " "	86
1 " "	26	2 " "	107
4 " "	27	2 " "	180
1 " "	42	2 " "	201

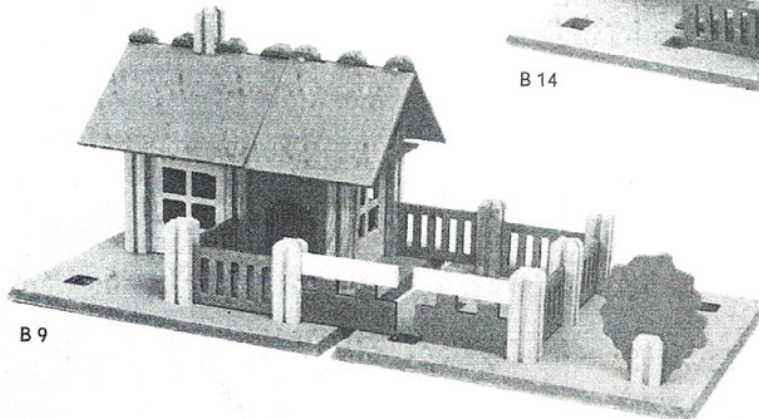

B 9

Weekend-huis B 9  
 Bungalow  
 Maison de week-end  
 Wochenend-Haus  
 Hacienda

6 x No.	1	1 x No.	60
6 " "	1 1/2	1 " "	62
2 " "	19	1 " "	70
3 " "	22	1 " "	76
1 " "	23	1 " "	84
5 " "	24	2 " "	107
4 " "	26	2 " "	124
2 " "	27	3 " "	180
1 " "	54	2 " "	201

DIESE MODELLE KÖNNEN GEBAUT WERDEN MIT KASTEN B ODER A + AB  
 DEZE MODELLEN KUNNEN GEBOUWD WORDEN MET DOOS B OF A + AB

**MOBACO**  
**B**

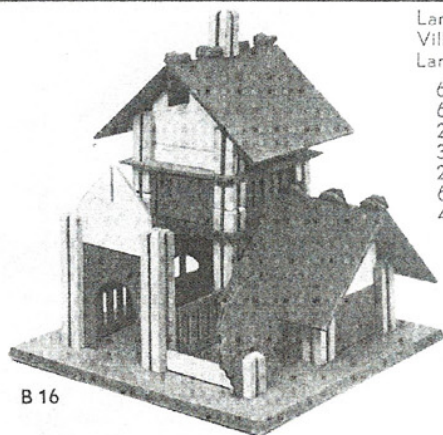

B 16

Landhuis		B 16	
Villa	Maison de campagne		
Landhaus	Casa de Campo		
6 x No. 1	3 x No. 27		
6 " " 1 1/2	1 " " 42		
2 " " 19	2 " " 54		
3 " " 22	1 " " 60		
2 " " 23	1 " " 62		
6 " " 24	1 " " 70		
4 " " 26	2 " " 76		
	1 " " 86		
	2 " " 107		
	2 " " 124		
	4 " " 180		
	1 " " 201		

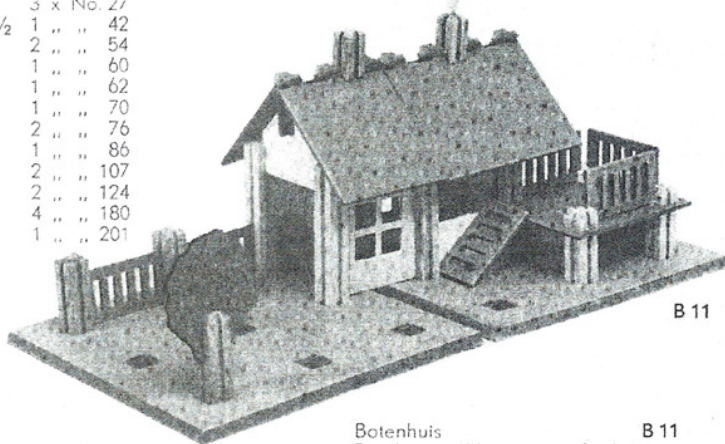

B 11

Boerderijtje B 5  
 Farm Petite ferme  
 Bauernhof Cortijo

4 x No. 1	
4 " " 1 1/2	
2 " " 22	
4 " " 24	
2 " " 26	
1 " " 86	
2 " " 107	
2 " " 180	
1 " " 201	

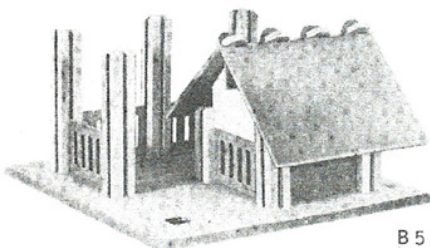

B 5

Botenhuis B 11  
 Boathouse Hangar pour les bateaux  
 Bootshaus Guarda botes

6 x No. 1	1 x No. 60
6 " " 1 1/2	1 " " 62
2 " " 19	1 " " 70
3 " " 22	2 " " 76
3 " " 23	1 " " 84
6 " " 24	2 " " 107
2 " " 26	2 " " 124
1 " " 27	3 " " 180
1 " " 42	2 " " 201
1 " " 54	

**MOBACO**  
**B**

THESE MODELS CAN BE BUILT WITH OUTFIT B OR A + AB  
 ESTOS MODELOS SE PUEDEN CONSTRUIR CON B O A + AB  
 CES MODELES PEUVENT ETRE CONSTRUITS AVEC LA BOÎTE B OU A + AB

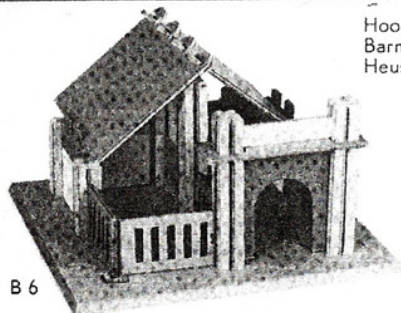

B 6

Hooischaar		B 6	
Barn	Grange		
Heuscheune	Henar		
4 x No. 1			
4 " " 1 1/2			
3 " " 22			
2 " " 23			
4 " " 24			
4 " " 26			
1 " " 27			
1 " " 42			
1 " " 54			
2 " " 107			
1 " " 201			

Fabriek		B 1	
Factory	Fabrique		
Fabrik	Fábrica		
4 x No. 1			
3 " " 1 1/2			
2 " " 24			
4 " " 26			
4 " " 27			
1 " " 62			
1 " " 70			
1 " " 201			

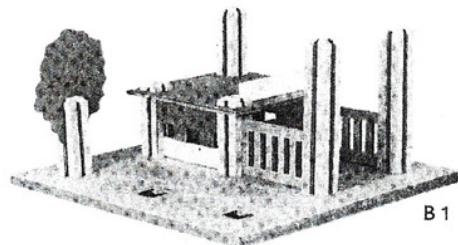

B 1

Villa met daktuin B 8  
 Villa with roofgarden Villa avec terrasse  
 Villa mit Dachgarten Villa con jardin

4 x No. 1	
4 " " 1 1/2	
2 " " 19	
2 " " 22	
3 " " 23	
4 " " 24	
2 " " 26	
1 " " 54	
1 " " 62	
1 " " 86	
2 " " 107	
2 " " 180	
1 " " 201	

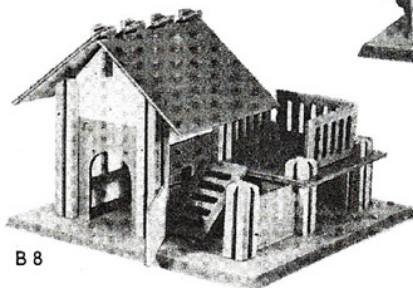

B 8

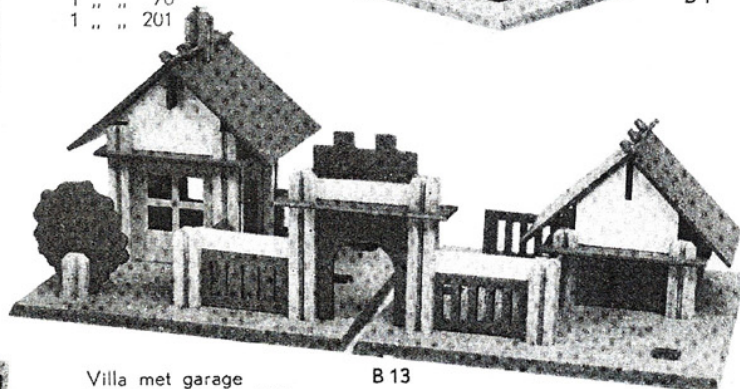

B 13

Villa met garage B 13  
 Villa with garage Villa avec garage  
 Villa mit Garage Villa con garage

6 x No. 1	2 x No. 26	1 x No. 70
6 " " 1 1/2	3 " " 27	2 " " 76
2 " " 19	1 " " 42	1 " " 86
2 " " 22	2 " " 54	2 " " 107
3 " " 23	1 " " 60	4 " " 124
6 " " 24	1 " " 62	4 " " 180
		2 " " 201

DEISE MODELLE KUNNEN GEBAUT WERDEN MIT KASTEN B ODER A + AB  
 DEZE MODELLEN KUNNEN GEBOUWD WORDEN MET DOOS B OF A + AB

# MOBACO B

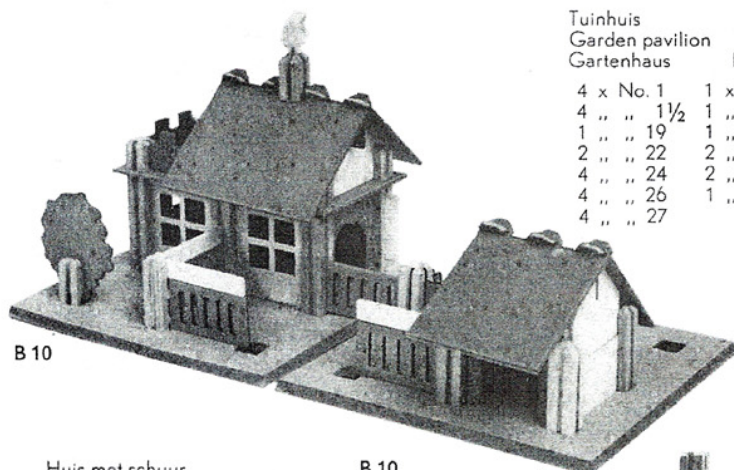

B 10

Tuinhuis Garden pavilion Gartenhaus	B 7 Pavillon Pabellón
4 x No. 1	1 x No. 54
4 " " 1½	1 " " 62
1 " " 19	1 " " 86
2 " " 22	2 " " 107
4 " " 24	2 " " 180
4 " " 26	1 " " 201
4 " " 27	

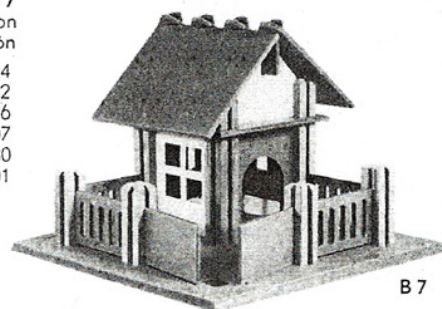

B 7

Huis met schuur  
House with shed  
Haus mit Scheune

B 10

Maison avec grange  
Casa con alpende

6 x No. 1	2 x No. 76
6 " " 1½	1 " " 86
2 " " 19	2 " " 107
3 " " 22	2 " " 124
3 " " 23	4 " " 180
6 " " 24	2 " " 201
4 " " 26	
4 " " 27	
2 " " 54	
1 " " 60	
1 " " 62	
1 " " 70	

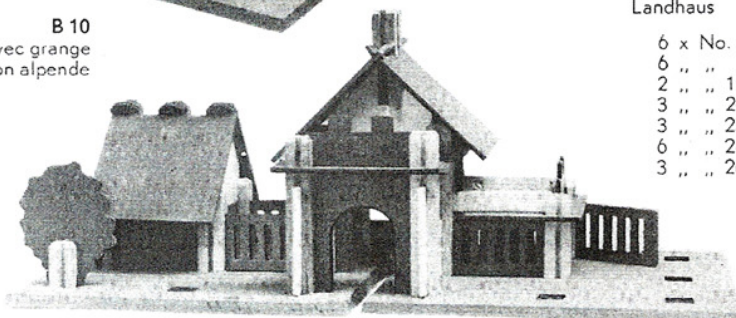

B 15

Buitenplaats  
Country house  
Landhaus

B 15

Propriété  
Casa de campo

6 x No. 1	4 x No. 27
6 " " 1½	1 " " 42
2 " " 19	2 " " 54
3 " " 22	1 " " 60
3 " " 23	1 " " 62
6 " " 24	1 " " 70
3 " " 26	2 " " 76
	1 " " 86
	2 " " 107
	2 " " 124
	4 " " 180
	2 " " 201

# MOBACO C

THESE MODELS CAN BE BUILT WITH OUTFIT C OR B + BC  
 ESTOS MODELOS SE PUEDEN CONSTRUIR CON C O B + BC  
 CES MODELES PEUVENT ETRE CONSTRUITS AVEC LA BOÎTE C OU B + BC

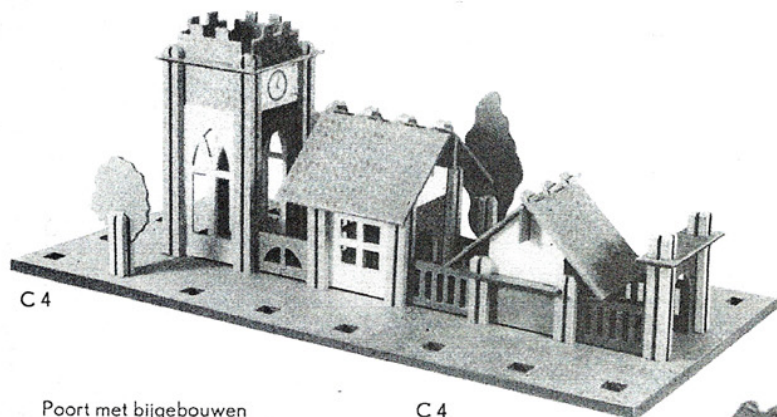

C 4

Poort met bijgebouwen  
Gatehouse with houses  
Stadttor

C 4

Porte avec annexes  
Puerta, casitas

6 x No. 1	2 x No. 54
6 " " 1½	1 " " 55
4 " " 2	1 " " 62
2 " " 14	1 " " 70
2 " " 15	1 " " 71
2 " " 19	1 " " 73
4 " " 22	1 " " 84
4 " " 23	1 " " 86
4 " " 24	2 " " 107
1 " " 25	2 " " 124
4 " " 26	4 " " 180
4 " " 27	1 " " 203
1 " " 42	

Kerk met bijgebouwen  
Church and churchhall  
Kirche mit Nebengebäude

C 2

Église avec presbytère  
Iglesia, casitas

4 x No. 1	2 x No. 19
6 " " 1½	4 " " 22
4 " " 2	4 " " 23
2 " " 14	4 " " 24
2 " " 15	1 " " 25
	4 " " 26
	4 " " 27
	1 " " 42
	2 " " 54
	1 " " 55
	1 " " 62
	1 " " 70
	1 " " 73
	1 " " 84
	1 " " 86
	2 " " 107
	2 " " 124
	1 " " 160
	4 " " 180
	1 " " 203

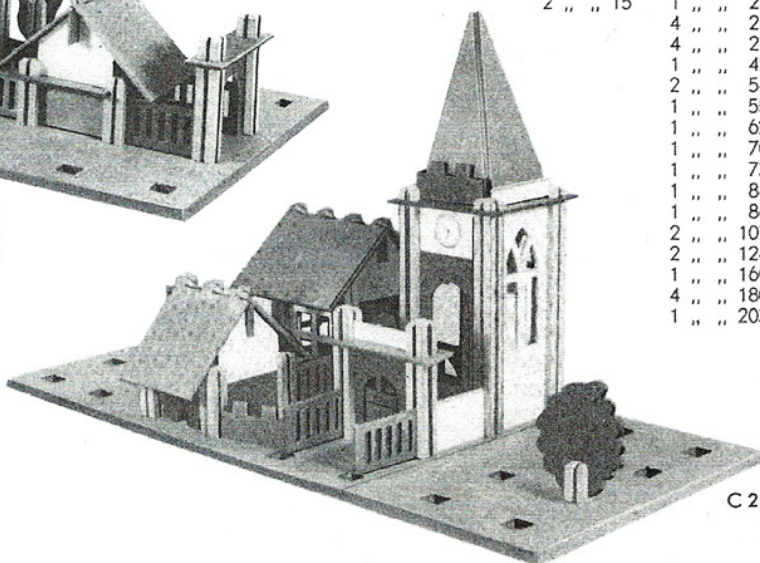

C 2

DIESE MODELLE KÖNNEN GEBAUT WERDEN MIT KASTEN C ODER B + BC.  
 DEZE MODELLEN KUNNEN GEBOUWD WORDEN MET DOOS C OF B + BC

**MOBACO**  
**C**

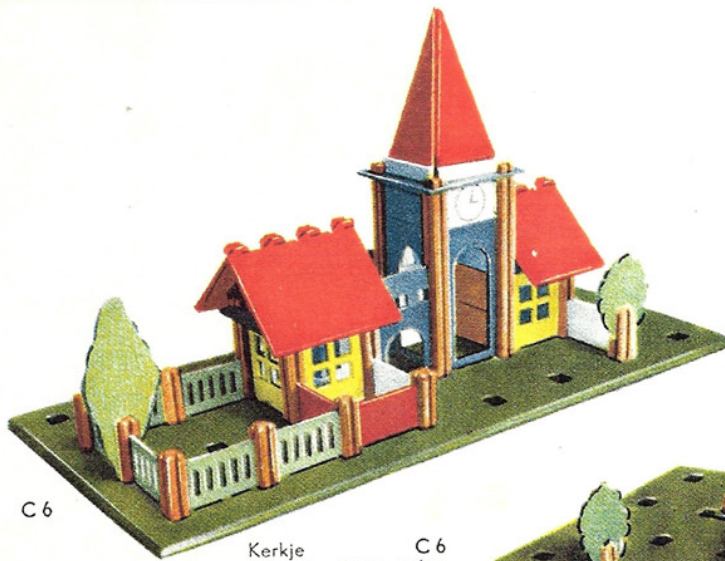

C6

Kerkje Church Kirche		Petite église Iglesia		C6	
8 x No.	1	1 x No.	25	1 x No.	71
6	1 1/2	4	26	1	73
4	2	4	27	1	86
2	14	1	42	2	107
1	15	2	54	2	124
2	19	1	55	1	160
4	22	1	60	4	180
4	23	1	62	1	203
8	24	1	70		

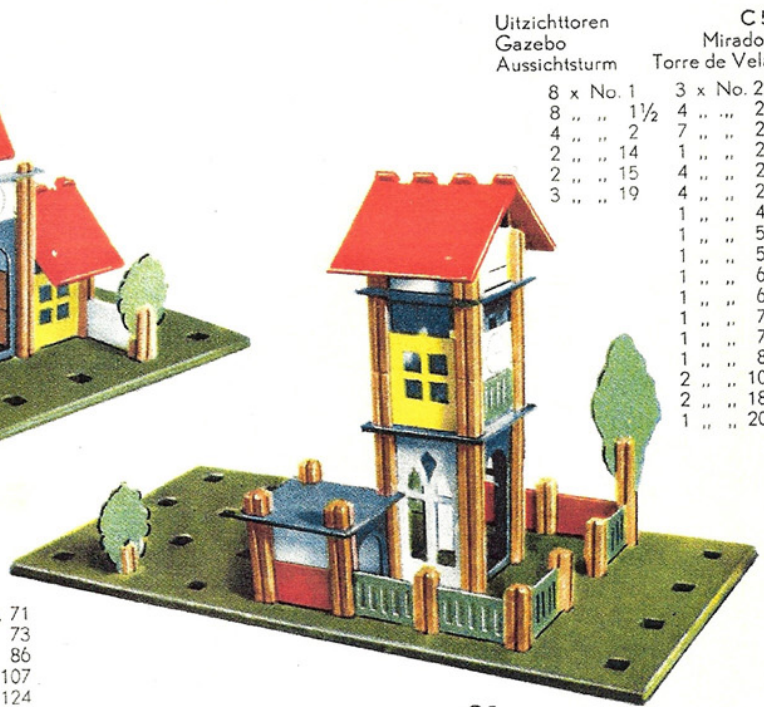

C5

Uitzichttoren Gazebo Aussichtsturm		C5 Mirador Torre de Vela	
8 x No.	1	3 x No.	22
8	1 1/2	4	23
4	2	7	24
2	14	1	25
2	15	4	26
3	19	4	27
		1	42
		1	54
		1	55
		1	60
		1	62
		1	71
		1	73
		1	86
		2	107
		2	180
		1	203

**MOBACO**  
**C**

THESE MODELS CAN BE BUILT WITH OUTFIT C OR B + BC.  
 ESTOS MODELOS SE PUEDEN CONSTRUIR CON C O B + BC.  
 CES MODELES PEUVENT ÊTRE CONSTRUITS AVEC LA BOÎTE C OU B + BC

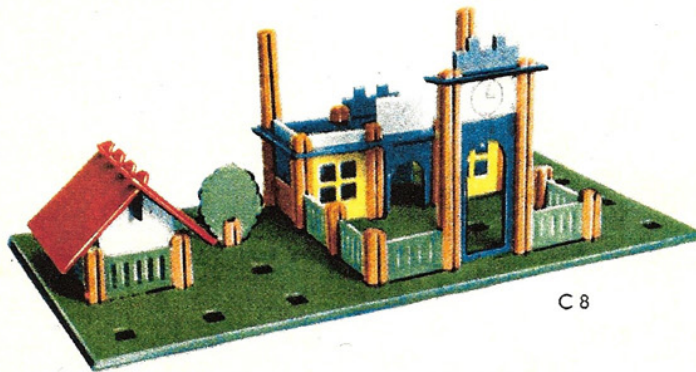

C8

Tramstation Tramway-station Bahnhof		C8 Gare de tramway Estación de Tranvía	
8 x No.	1	2 x No.	54
6	1 1/2	1	55
4	2	1	60
1	14	1	62
3	19	1	70
4	22	1	73
3	23	1	76
8	24	1	86
1	25	2	107
4	26	2	180
4	27	1	203
1	42		

Kerk met pastorie Church with vicarage Kirche mit Pfarrhaus		C7 Église avec annexes Iglesia	
8 x No.	1	3 x No.	19
8	1 1/2	4	22
4	2	4	23
2	14	4	24
2	15	1	25
		3	26
		4	27
		1	42
		2	54
		1	60
		1	62
		1	71
		1	73
		1	76
		1	86
		2	107
		2	124
		1	160
		4	180
		1	203

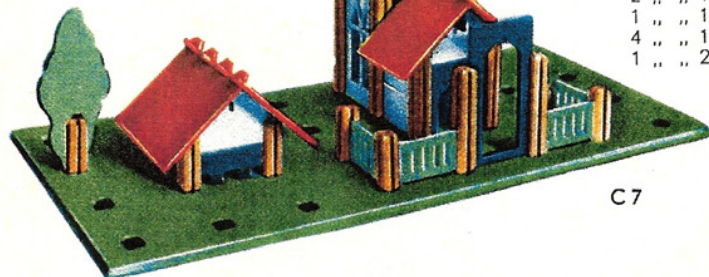

C7

DIESE MODELLE KÖNNEN GEBAUT WERDEN MIT KASTEN C ODER B + BC  
 DEZE MODELLEN KUNNEN GEBOUWD WORDEN MET DOOS C OF B + BC

# MOBACO C

		C 10			
		Fabriek	Fabrique		
		Fabrik	Fábrica		
5 x	No. 1	1 x	No. 25	1 x	No. 70
8 "	" 1 1/2	4 "	" 26	1 "	" 76
2 "	" 2	4 "	" 27	1 "	" 84
3 "	" 19	1 "	" 42	2 "	" 107
4 "	" 22	2 "	" 54	2 "	" 124
4 "	" 23	1 "	" 60	2 "	" 180
4 "	" 24	1 "	" 62	1 "	" 203

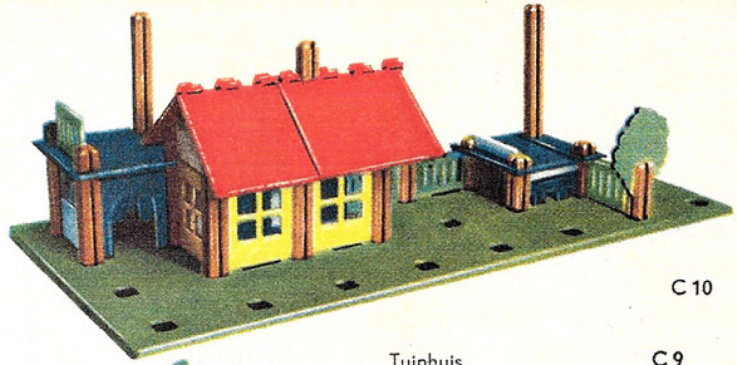

C 10

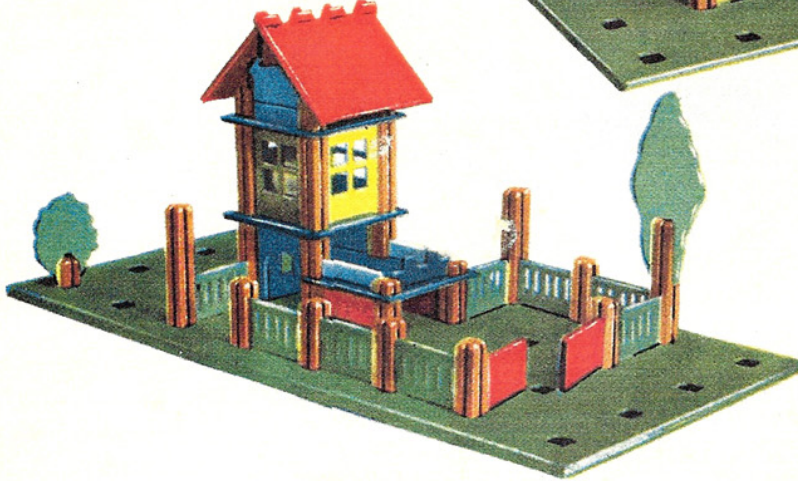

		C 9	
		Tuinhuis	Gloriette
		Pavilion	Pabellón de jardín
		Gartenhaus	
8 x	No. 1	1 x	No. 54
3 "	" 1 1/2	1 "	" 55
4 "	" 2	1 "	" 60
3 "	" 19	1 "	" 62
4 "	" 22	1 "	" 70
4 "	" 23	1 "	" 71
8 "	" 24	2 "	" 76
1 "	" 25	1 "	" 86
3 "	" 26	2 "	" 107
4 "	" 27	2 "	" 180
1 "	" 42	1 "	" 203

# MOBACO D

THESE MODELS CAN BE BUILT WITH OUTFIT D OR C + CD  
 ESTOS MODELOS SE PUEDEN CONSTRUIR CON D O C + CD  
 CES MODELES PEUVENT ÊTRE CONSTRUITS AVEC LA BOÎTE D OU C + CD

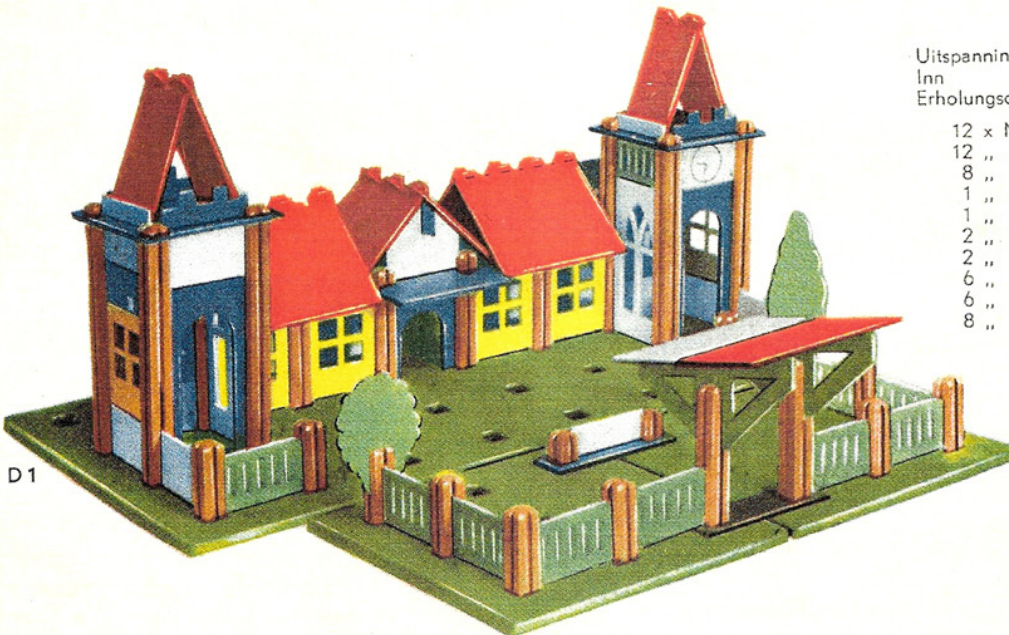

D1

		D 1	
		Uitspanning	Auberge
		Inn	Casa de recreo
		Erholungsort	
12 x	No. 1	10 x	No. 24
12 "	" 1 1/2	4 "	" 25
8 "	" 2	12 "	" 26
1 "	" 11	8 "	" 27
1 "	" 12	5 "	" 28
2 "	" 14	2 "	" 42
2 "	" 15	3 "	" 54
6 "	" 19	2 "	" 55
6 "	" 22	2 "	" 60
8 "	" 23	2 "	" 62
		1 "	" 63
		1 "	" 70
		1 "	" 71
		1 "	" 73
		2 "	" 76
		2 "	" 84
		1 "	" 86
		2 "	" 89
		4 "	" 107
		2 "	" 124
		4 "	" 133
		4 "	" 180
		2 "	" 201
		1 "	" 203

DIESE MODELLE KÖNNEN GEBAUT WERDEN MIT KASTEN D ODER C + CD  
 DEZE MODELLEN KUNNEN GEBOUWD WORDEN MET DOOS D OF C + CD

**MOBACO**  
**D**

Kasteeltje met ophaalbrug D 2  
 Castle with drawbridge  
 Château avec pont  
 Schloss mit Brücke  
 Castillo con puente levadizo

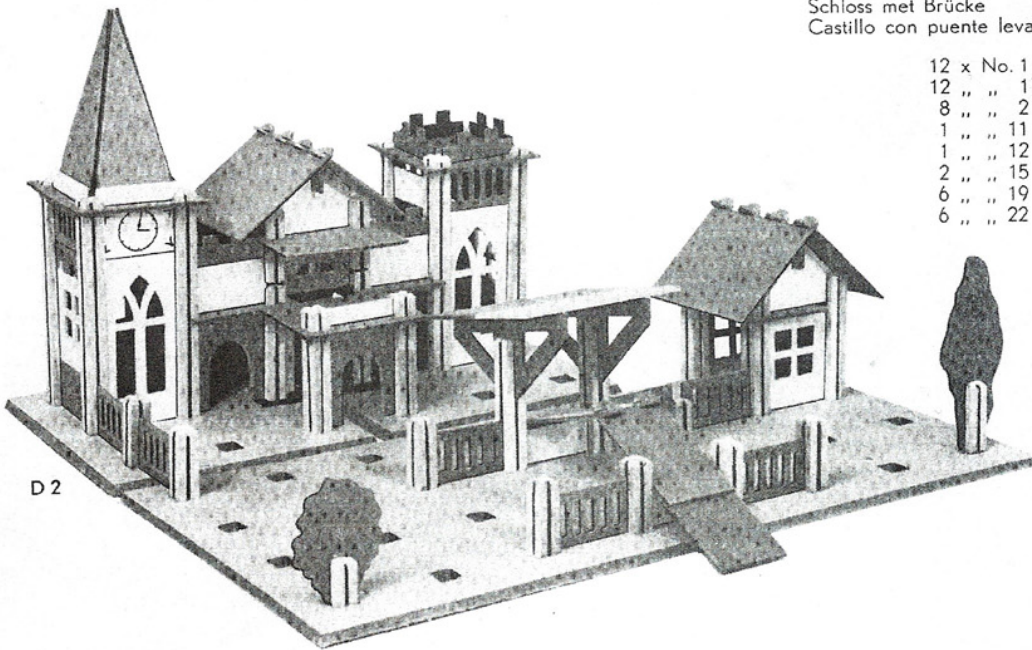

12 x No. 1	8 x No. 23
12 " " 1½	12 " " 24
8 " " 2	4 " " 25
1 " " 11	12 " " 26
1 " " 12	5 " " 27
2 " " 15	5 " " 28
6 " " 19	2 " " 42
6 " " 22	3 " " 54
	2 " " 55
	2 " " 60
	2 " " 62
	1 " " 63
	1 " " 70
	1 " " 71
	1 " " 73
	2 " " 76
	2 " " 86
	2 " " 89
	4 " " 107
	4 " " 133
	1 " " 160
	4 " " 180
	2 " " 201
	1 " " 203

**MOBACO**  
**D**

THESE MODELS CAN BE BUILT WITH OUTFIT D OR C + CD  
 ESTOS MODELOS SE PUEDEN CONSTRUIR CON D O C + CD  
 GES MODÈLES PEUVENT ÊTRE CONSTRUITS AVEC LA BOÎTE D OU C + CD

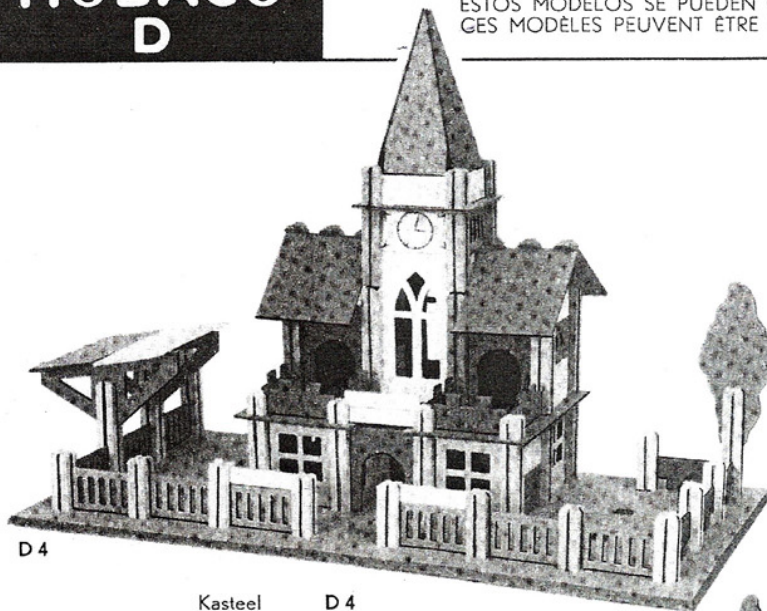

Kasteel		D 4		Castle		Château		Schloss		Castillo	
11 x No. 1	12 x No. 24	1 x No. 71									
12 " " 1½	4 " " 25	1 " " 73									
8 " " 2	12 " " 26	2 " " 86									
1 " " 11	4 " " 27	2 " " 89									
1 " " 12	6 " " 28	4 " " 124									
2 " " 15	3 " " 54	1 " " 160									
5 " " 19	2 " " 55	4 " " 180									
6 " " 22	2 " " 62	1 " " 203									
8 " " 23	1 " " 63										

Stadhuis  
 Townhall  
 Rathaus

D 5  
 Mairie  
 Ayuntamiento

11 x No. 1	3 x No. 54
12 " " 1½	1 " " 55
8 " " 2	2 " " 62
1 " " 11	1 " " 63
1 " " 12	1 " " 70
2 " " 14	1 " " 71
2 " " 15	1 " " 73
6 " " 19	2 " " 84
5 " " 22	2 " " 89
6 " " 23	2 " " 107
12 " " 24	4 " " 124
4 " " 25	2 " " 133
12 " " 26	1 " " 160
8 " " 27	4 " " 180
6 " " 28	1 " " 203

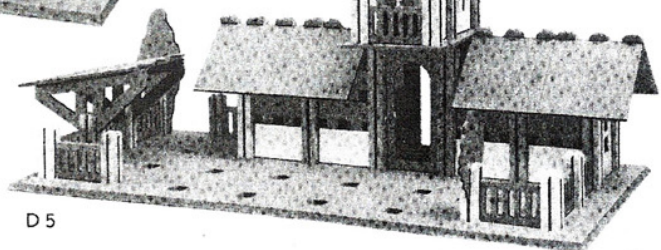

DIESE MODELLE KÖNNEN GEBAUT WERDEN MIT KASTEN D ODER C + CD  
 DEZE MODELLEN KUNNEN GEBOUWD WORDEN MET DOOS D OF C + CD

# MOBACO D

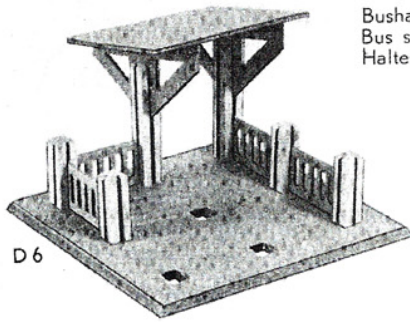

D6

Bushalte D6  
 Bus shelter Arrêt d'autobus  
 Haltestelle Parada de Autobuses

4 x No. 1
2 " " 1½
1 " " 11
1 " " 12
4 " " 24
2 " " 89
1 " " 201

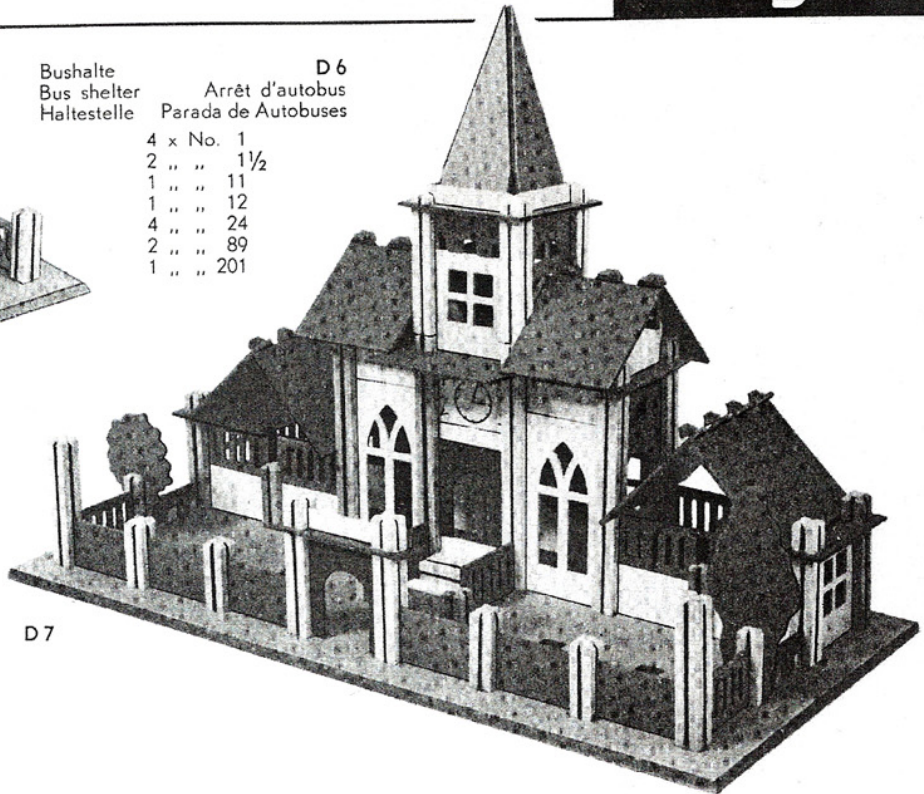

D7

Schoolgebouw D7  
 School École  
 Schule Escuela

10 x No. 1	2 x No. 54
12 " " 1½	2 " " 55
8 " " 2	2 " " 60
1 " " 11	1 " " 62
2 " " 14	1 " " 63
2 " " 15	1 " " 70
6 " " 19	1 " " 71
6 " " 22	1 " " 73
8 " " 23	2 " " 76
12 " " 24	2 " " 86
4 " " 25	4 " " 107
8 " " 26	4 " " 124
8 " " 27	1 " " 160
5 " " 28	4 " " 180
1 " " 42	1 " " 203

# MOBACO E

THESE MODELS CAN BE BUILT WITH OUTFIT E OR D + DE  
 ESTOS MODELOS SE PUEDEN CONSTRUIR CON E O D + DE  
 CES MODELES PEUVENT ÊTRE CONSTRUITS AVEC LA BOÎTE E OU D + DE

12 x No. 1
12 " " 1½
8 " " 2
4 " " 3
2 " " 11
2 " " 12
3 " " 14
4 " " 15
2 " " 18

6 x No. 19
3 " " 20
4 " " 22
6 " " 23
14 " " 24
2 " " 26
8 " " 27
5 " " 28
4 " " 41

Dorpje E2  
 Village Village  
 Dörfchen Aldea

4 x No. 45	2 x No. 103
2 " " 54	4 " " 107
1 " " 55	2 " " 123
2 " " 62	2 " " 124
1 " " 63	1 " " 143
1 " " 65	1 " " 160
3 " " 70	4 " " 180
2 " " 71	2 " " 182
1 " " 73	1 " " 200
4 " " 76	1 " " 201
4 " " 84	1 " " 202
1 " " 86	1 " " 203

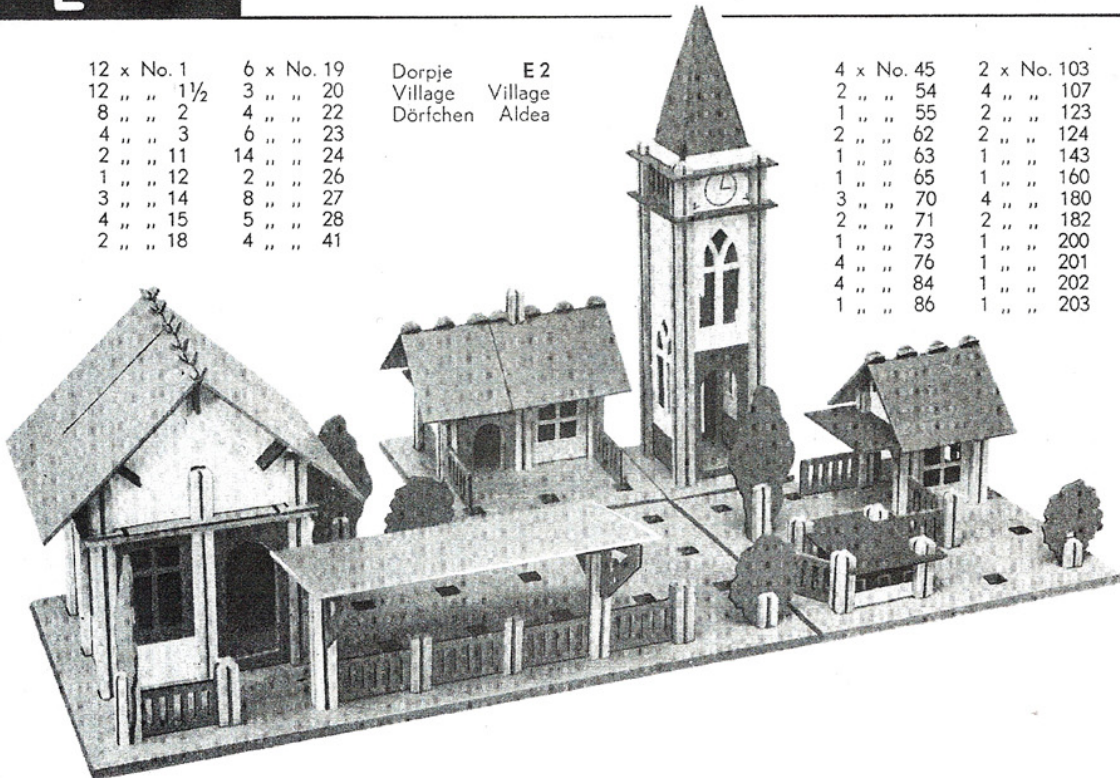

DIESE MODELLE KÖNNEN GEBAUT WERDEN MIT KASTEN E  
DEZE MODELLEN KUNNEN GEBOUWD WORDEN MET DOOS

ODER D + DE  
E OF D + DE

# MOBACO E

Dorpskerkje Village church Dorfkirche		E3 Église de village Iglesia del Pueblo	
12 x No. 1	4 x No. 76		
12 " " 1½	1 " " 86		
8 " " 2	2 " " 89		
4 " " 3	2 " " 107		
2 " " 11	1 " " 160		
4 " " 14	2 " " 180		
4 " " 15	1 " " 201		
3 " " 19	1 " " 202		
4 " " 20	1 " " 203		
4 " " 22			
6 " " 23			
16 " " 24			
4 " " 25			
10 " " 26			
7 " " 27			
4 " " 28			
1 " " 42			
3 " " 54			
2 " " 60			
1 " " 62			
1 " " 63			
1 " " 68			
3 " " 70			
3 " " 71			
1 " " 73			

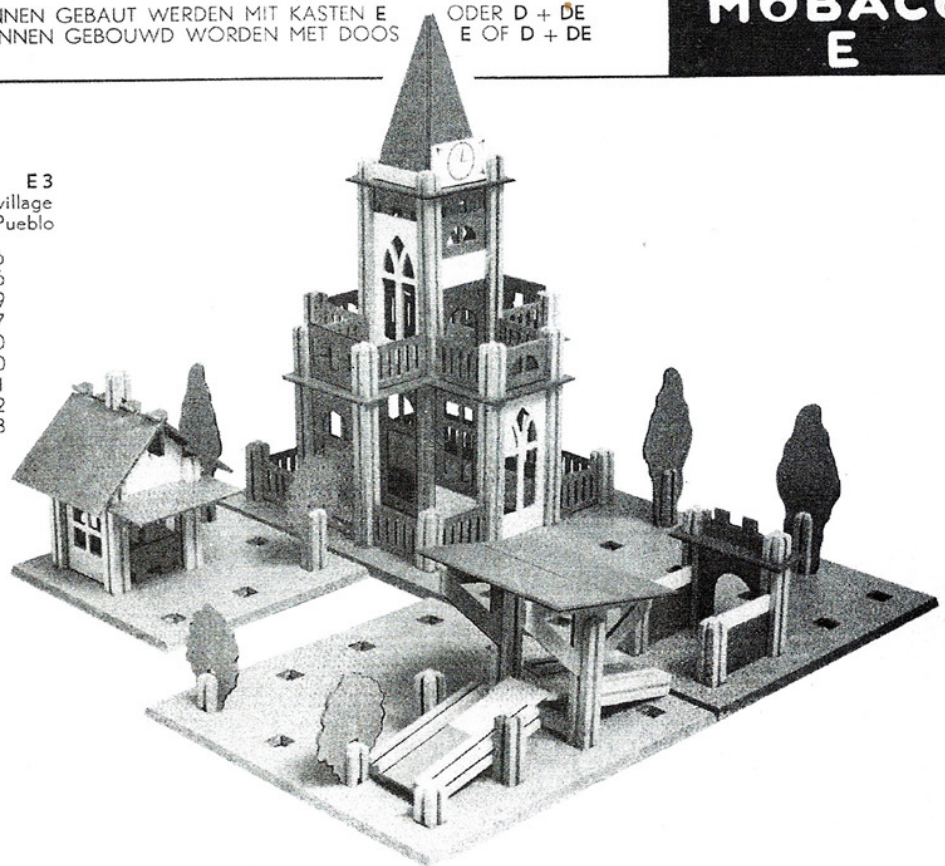

# MOBACO E

THESE MODELS CAN BE BUILT WITH OUTFIT E OR D + DE  
ESTOS MODELOS SE PUEDEN CONSTRUIR CON E O D + DE  
CES MODÈLES PEUVENT ÊTRE CONSTRUITS AVEC LA BÔÎTE E OU D + DE

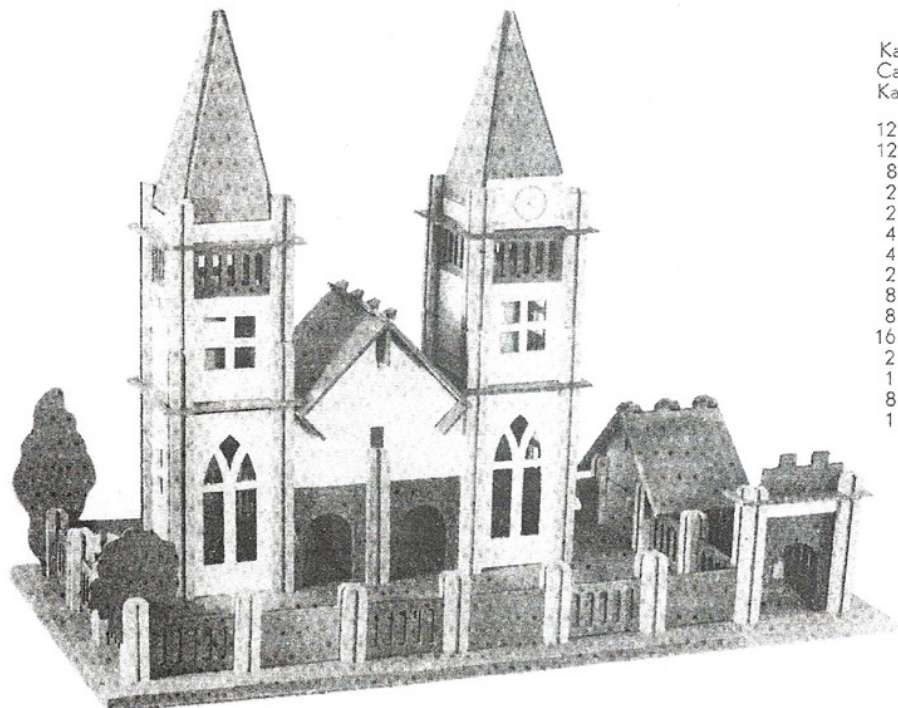

Kathedraal Cathedral Kathedrale		E4 Cathédrale Catedral	
12 x No. 1	3 x No. 54		
12 " " 1½	1 " " 55		
8 " " 2	3 " " 62		
2 " " 12	1 " " 70		
2 " " 14	1 " " 71		
4 " " 15	1 " " 73		
4 " " 19	4 " " 76		
2 " " 21	3 " " 84		
8 " " 22	1 " " 86		
8 " " 23	2 " " 107		
16 " " 24	2 " " 124		
2 " " 25	2 " " 160		
1 " " 26	2 " " 180		
8 " " 27	2 " " 182		
1 " " 42	1 " " 203		



DIESE MODELLE KÖNNEN GEBAUT WERDEN MIT KASTEN E ODER D + DE  
 DEZE MODELLEN KUNNEN GEBOUWD WORDEN MET DOOS E OF D + DE

# MOBACO E

Zwembad	E 5
Swimming-bath	Piscine
Schwimmbad	Piscina
11 x No. 1	
12 " " 1½	
8 " " 2	
4 " " 3	
2 " " 11	
2 " " 14	
2 " " 18	
5 " " 19	
2 " " 20	
10 " " 22	
12 " " 23	
16 " " 24	
4 " " 25	

10 x No. 26	2 x No. 62	4 x No. 86
7 " " 27	1 " " 63	2 " " 103
4 " " 28	1 " " 65	2 " " 107
2 " " 45	1 " " 68	1 " " 133
1 " " 48	3 " " 70	2 " " 180
3 " " 54	3 " " 71	2 " " 182
2 " " 55	1 " " 73	1 " " 202
2 " " 60	4 " " 76	1 " " 203

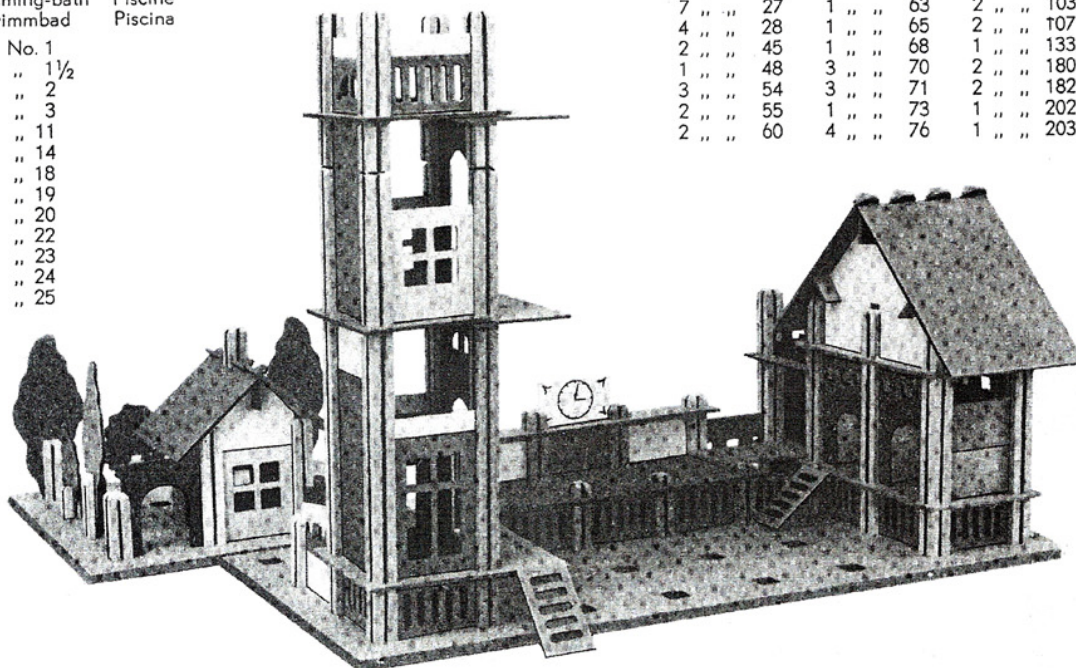

# MOBACO E

THESE MODELS CAN BE BUILT WITH OUTFIT E OR D + DE  
 ESTOS MODELOS SE PUEDEN CONSTRUIR CON E O D + DE  
 CES MODELES PEUVENT ÊTRE CONSTRUITS AVEC LA BOÎTE E OU D + DE

Stationsgebouw	E 6
Railway-station	Gare
Bahnhof	Estación
12 x No. 1	9 x No. 22
12 " " 1½	10 " " 23
8 " " 2	14 " " 24
4 " " 3	4 " " 25
2 " " 11	4 " " 26
2 " " 12	6 " " 27
4 " " 14	2 " " 28
6 " " 19	4 " " 45
4 " " 20	3 " " 54
2 " " 21	2 " " 60

2 x No. 62	2 x No. 89
1 " " 63	1 " " 103
1 " " 65	3 " " 107
1 " " 68	2 " " 124
3 " " 70	1 " " 143
1 " " 71	4 " " 180
1 " " 73	2 " " 182
4 " " 76	1 " " 202
1 " " 84	1 " " 203
4 " " 86	

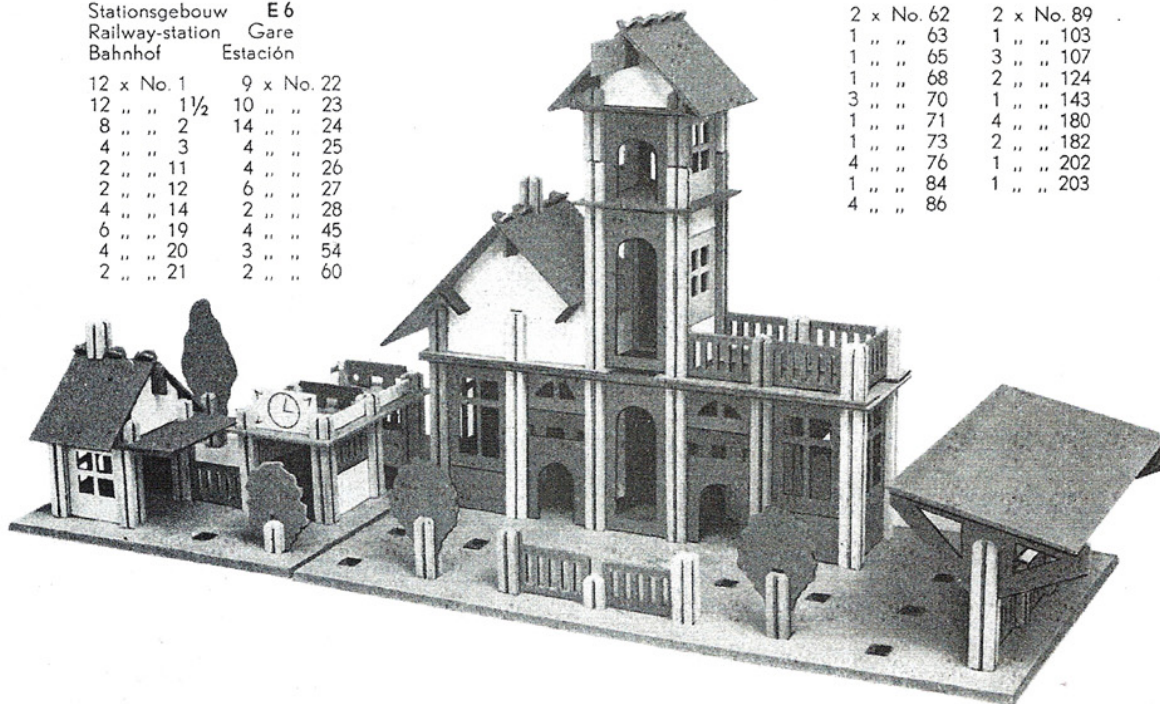

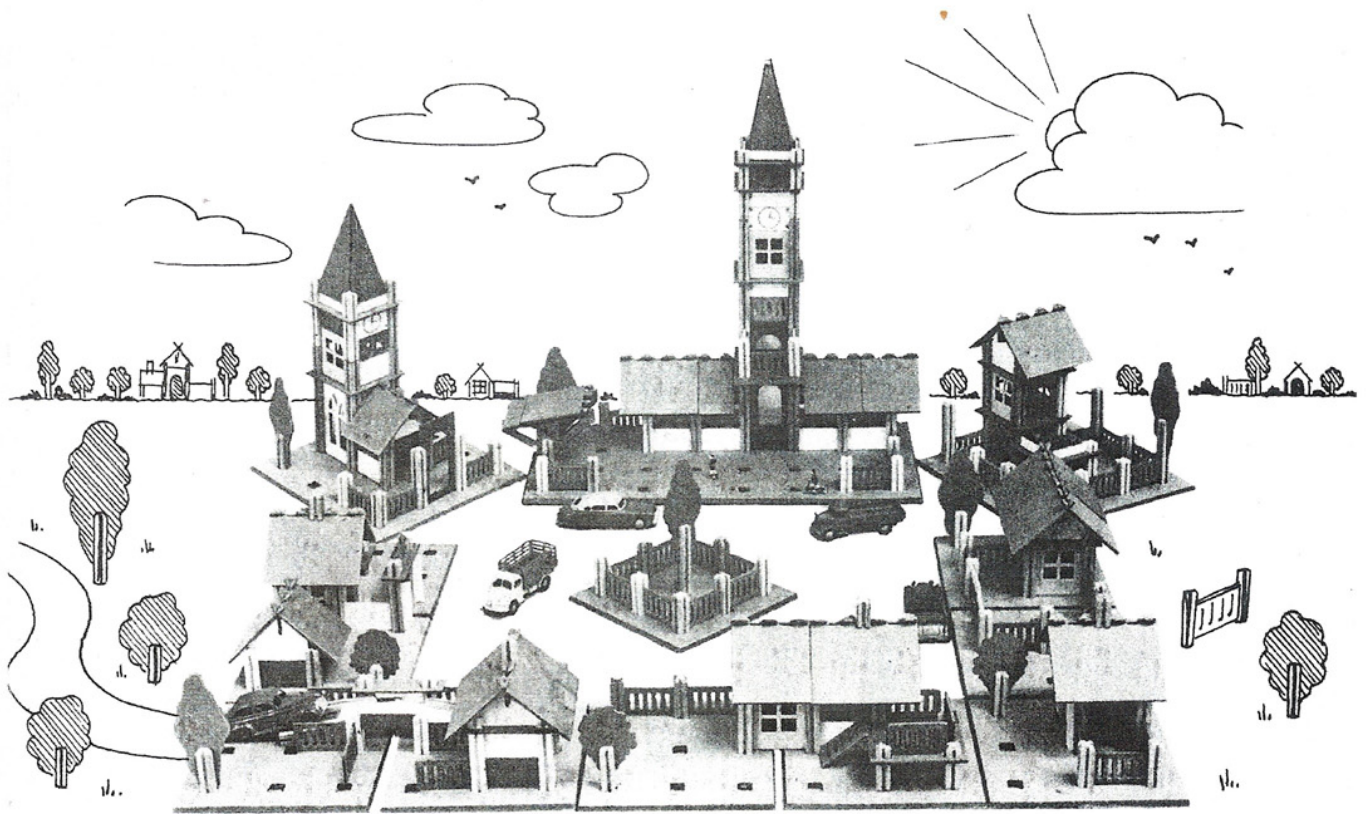

CONTENTS OF THE VARIOUS MOBACO OUTFITS  
 CONTENIDO DE LAS DIFERENTES CAJAS MOBACO  
 TABLE DES ACCESSOIRES DE MOBACO  
 TAFEL MIT DEN VERSCHIEDENEN MOBACO TEILEN  
 INHOUD DER VERSCHILLENDE MCBACO DOZEN

No.	A	AB	B	BC	C	CD	D	DE	E
1	2	4	6	2	8	4	12	—	12
1½	4	2	6	2	8	4	12	—	12
2	—	—	—	4	4	4	8	—	8
3	—	—	—	—	—	—	—	4	4
11	—	—	—	—	—	1	1	—	2
12	—	—	—	—	—	1	1	—	2
14	—	—	—	2	2	—	2	—	4
15	—	—	—	2	2	—	2	—	4
18	—	—	—	—	—	—	—	2	2
19	1	1	2	1	3	3	6	—	6
20	—	—	—	—	—	—	—	4	4
21	—	—	—	—	—	—	—	2	2
22	2	1	3	1	4	2	6	—	10
23	2	1	3	1	4	4	8	—	12
24	2	4	6	2	8	4	12	—	16
25	—	—	—	1	1	3	4	—	4
26	—	4	4	—	4	8	8	—	12
27	—	4	4	—	4	4	8	—	8
28	—	—	—	—	—	6	6	—	6
40	—	—	—	—	—	—	—	4	4
41	—	—	—	—	—	—	—	4	4
42	—	1	1	—	1	1	2	—	2
44	—	—	—	—	—	—	—	2	2
45	—	—	—	—	—	—	—	4	4
48	—	—	—	—	—	—	—	2	2
54	1	1	2	—	2	1	3	—	3
55	—	—	—	1	1	1	2	—	2
60	—	1	1	—	1	1	2	—	2
62	1	—	—	—	1	1	2	1	3
63	—	—	—	—	—	—	1	—	1
65	—	—	—	—	—	—	—	1	1
68	—	—	—	—	—	—	—	1	1
70	1	—	1	—	1	—	1	2	3
71	—	—	—	1	1	—	1	—	3
73	—	—	—	1	1	—	1	—	1
76	1	1	2	—	2	—	2	2	4
84	—	1	1	—	1	—	2	2	4
85	—	—	—	—	—	1	2	2	4
86	—	1	1	—	1	—	2	2	4
89	—	—	—	—	—	—	—	—	—
103	—	—	—	—	—	—	—	2	2
107	2	—	2	—	2	2	4	—	4
123	—	—	—	—	—	—	—	2	2
124	—	2	2	—	2	2	4	—	4
133	—	—	—	—	—	—	—	4	4
143	—	—	—	—	—	—	—	1	1
160	—	—	—	—	—	—	—	1	1
180	2	2	4	—	4	—	4	—	4
182	—	—	—	—	—	—	—	2	2
200	—	—	—	—	—	—	—	2	1
201	1	1	2	—	2	—	2	—	2
202	—	—	—	—	—	—	—	1	1
203	—	—	—	1	1	—	1	—	1

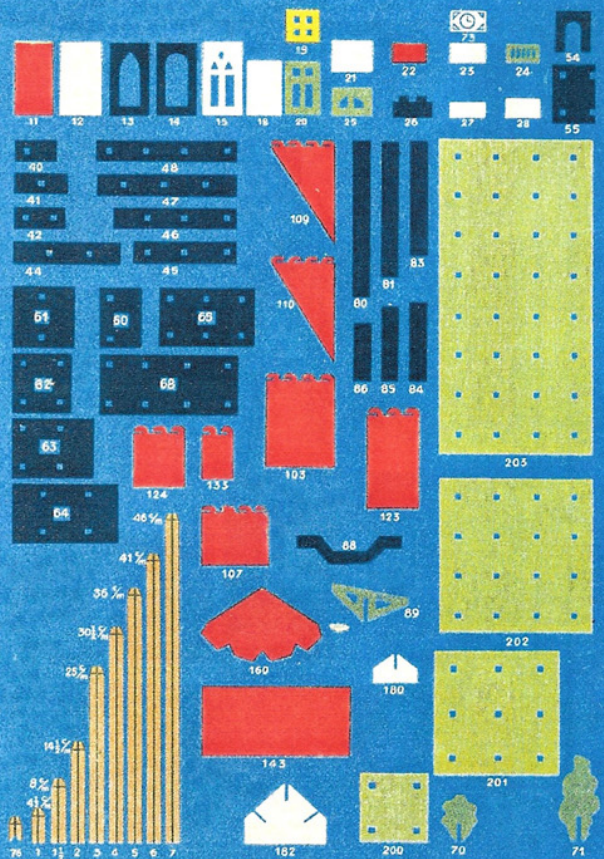

COPYRIGHT: HAUSEMANN & HOTTE N.V. AMSTERDAM

# GARAGE

PRODUIT NÉERLANDAIS

MADE IN HOLLAND

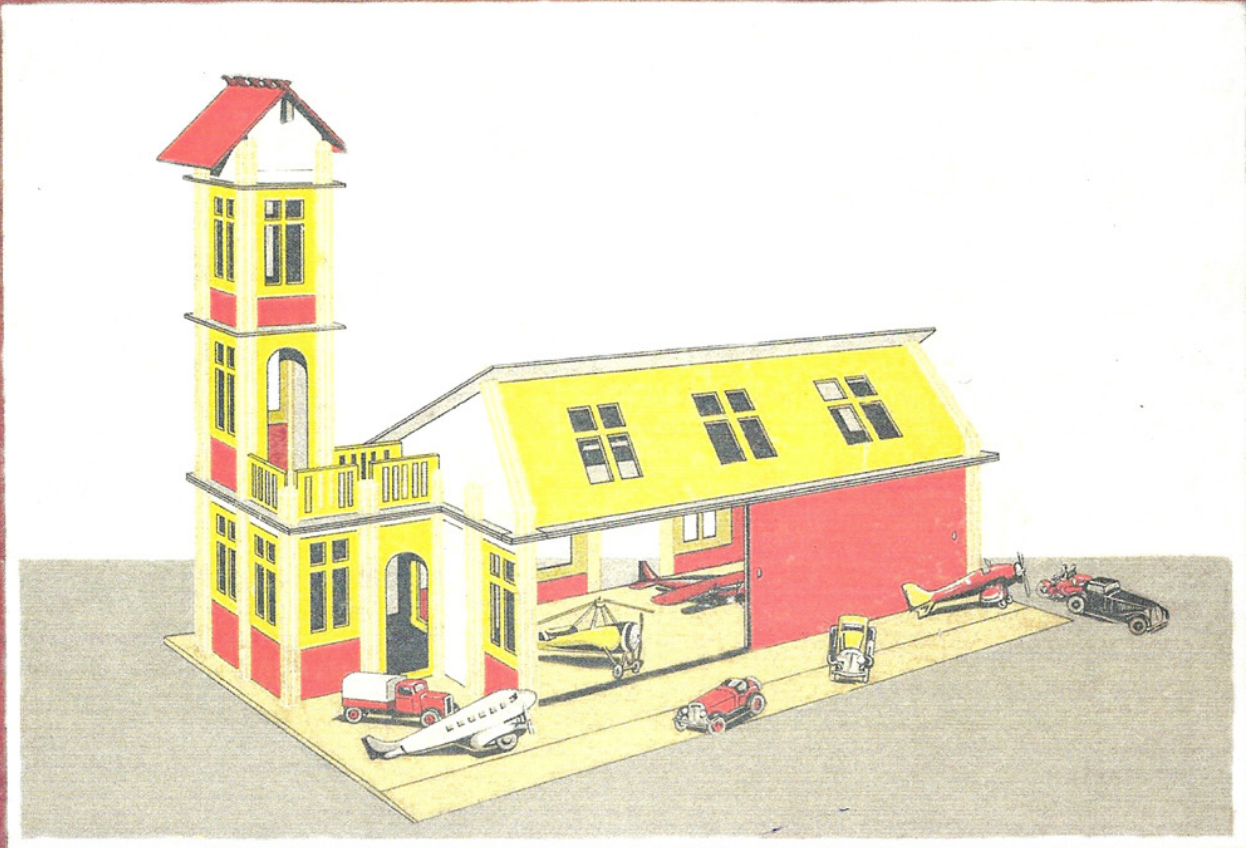

PRODUCCION HOLANDESA

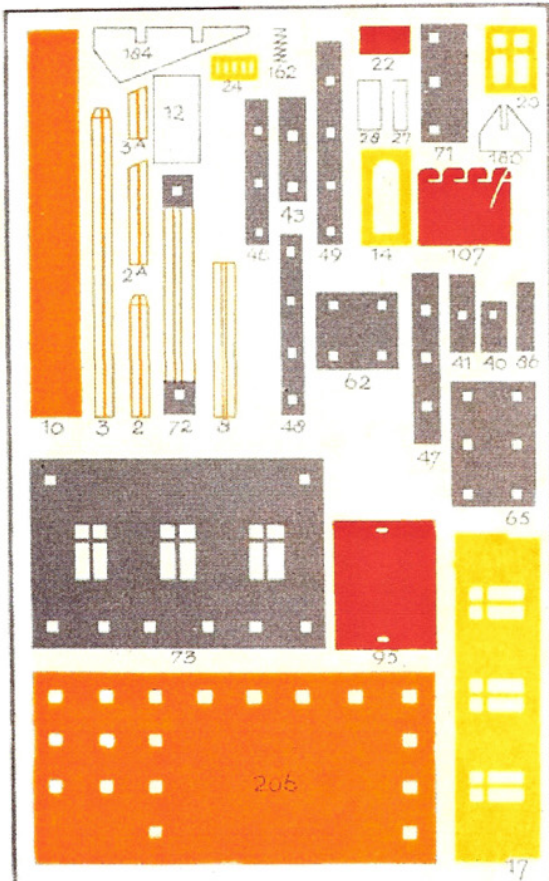

## MOBACO GARAGE No 1

No	No	No	No	No	No
2	12	24	4	65	1
2 <sup>A</sup>	2	27	19	71	1
3	4	28	2	72	1
3 <sup>A</sup>	2	40	1	73	1
8	1	41	1	86	1
10	1	43	1	95	2
12	5	46	3	107	2
14	4	47	1	162	2
17	1	48	1	180	2
20	12	49	1	184	2
22	12	62	1	206	1

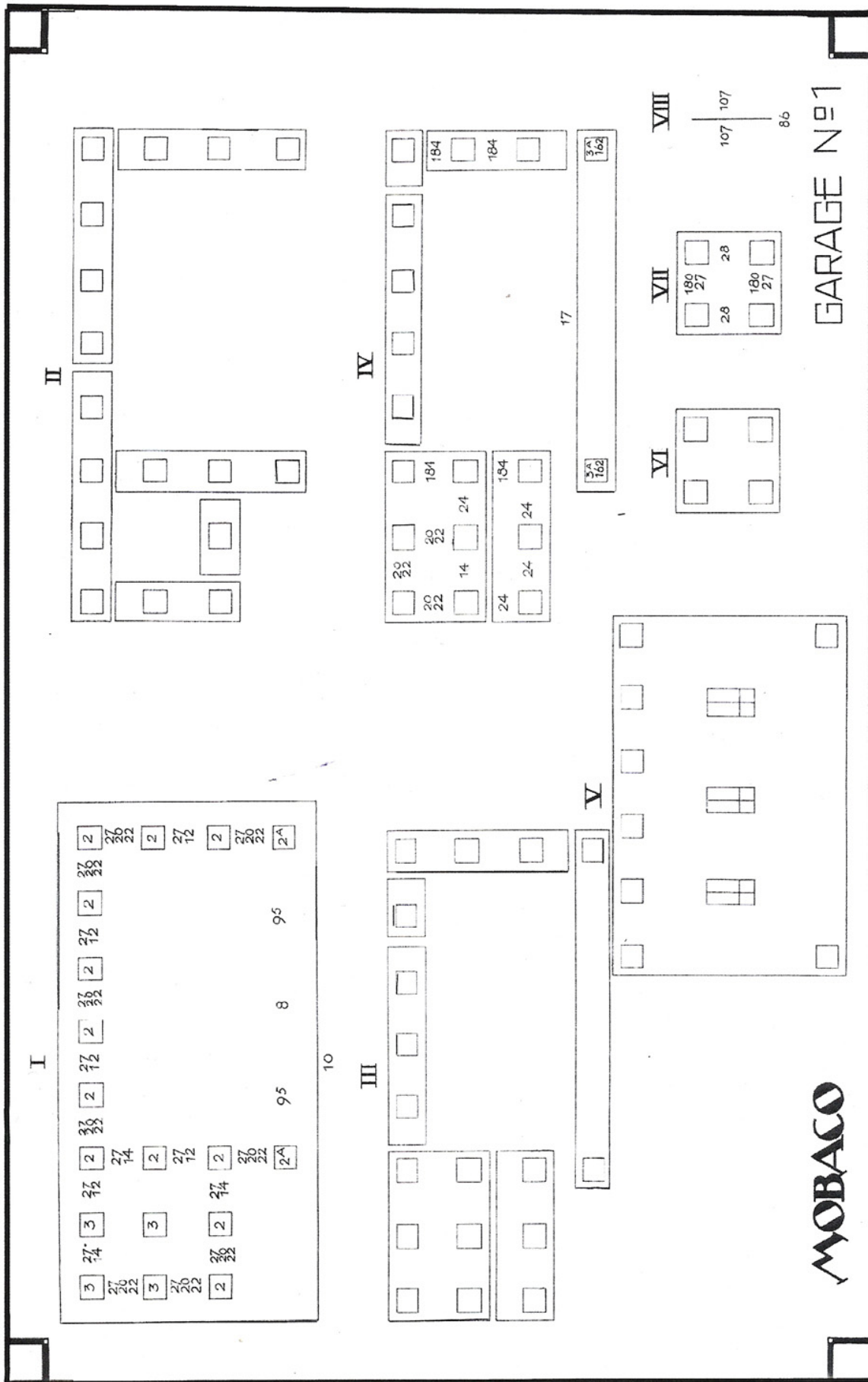

# MOLEN



## DE HOLLANDSCHE MOLEN

De fabrikante van het bekende MOBACO speelgoed heeft het voornemen opgevat om naast de MOBACO doozen, een geheel nieuwe serie uit hard-cartonnen onderdeelen vervaardigde bouwdoozen te ontwerpen, waaruit een volledig gebouw samengesteld kan worden.

Als eerste van deze serie werd „een Hollandsche molen” gekozen, waarvan een groot en een klein model zal worden uitgebracht.

Het ligt in de bedoeling deze serie te vervolgen met andere typisch Hollandsche gebouwen, om zoo-doende een bijzondere attractie en tevens een alleraardigst speelgoed voor de kinderen te vormen.

### DOOSINHOUD :

#### „DE HOLLANDSCHE MOLEN”

- 1 groote bruine grondplaat.
  - 1 kleine bruine grondplaat.
  - 8 witte ondermuurdeelen.
  - 8 groene hekjes.
  - 8 roode rompstukken.
  - 1 grijs plafond.
  - 1 houten molenkap.
  - 1 wit staartstuk.
  - 1 messing schroef.
  - 1 messing pijpje.
  - 1 messing sluitring.
  - 1 messing klemplaatje.
  - 2 houten wieken.
  - 4 witte wiekzeilen.
- Totaal 39 onderdeelen.

### BOUWVOORSCHRIFT:

1. Plaats op de kleine bruine grondplaat in de daarvoor bestemde sleuven de 8 witte ondermuurdeelen met de breede uitstekende gedeelten beneden.
2. Op deze 8 opgezette witte ondermuurdeelen kan de groote grondplaat met de dubbele rij sleuven geplaatst worden. In de buitenste sleuven worden de groene hekjes gestoken.
3. Naast elkaar met het breede gedeelte onder worden de roode rompstukken geplaatst in dezelfde sleuven, als waarin de witte ondermuurstukken geschoven zijn. — Om deze rompstukken stevig bij elkaar te houden, wordt het grijze plafond op de bovengedeelten van deze rompstukken geschoven.
4. De houten kap kan nu geplaatst worden, met het daarin geschoven witte staartstuk. Thans dienen alleen nog de wieken aangebracht te worden.
5. De wieken zijn onderling verbonden door een messing pijpje, wat het draaien straks zeer vergemakkelijkt. In de houten sleuven zijn reeds de witte wiekzeilen geschoven. Teneinde de wieken de juiste stand te laten behouden, zijn zij verbonden door een messing klemplaatje.
6. Het wiekenstel kan dus direct in de molenkap aangebracht worden. Dit geschiedt door de messing schroef. Tusschen de houten kap en de wieken moet echter het messing sluitringetje aangebracht worden, teneinde het licht draaien te bevorderen. Thans is de molen gereed. Denk eraan, dat de wieken van de molen altijd draaien in tegengestelde richting van de wijzers van het uurwerk, gezien van voren.

Ten einde een ander effect te bereiken, kan de groote bruine grondplaat met de kleine bruine grondplaat omgewisseld worden.

In de grondplaten zijn vierkante gaten aangebracht, hetgeen mogelijk maakt de molen te monteeren en in combinatie te bouwen met de bekende gebouwen uit de MOBACO Serie, terwijl door aanschaffing van een grondplaat no. 203 à 40 cts. de molen no. 1 (klein model) en no. 2 (groot model) een schuur of huis uit de doozen nos. 000-00-0-01-1 en 2 naast de molen gebouwd kunnen worden, zooals b.v. op het etiket van de doos is aangegeven.

---

N.V. PLAATMETAALINDUSTRIE VAN MOUWERIK & BAL — ZEIST

# DE HOLLANDSCHE MOLEN

DEUTSCH NEDERLANDS

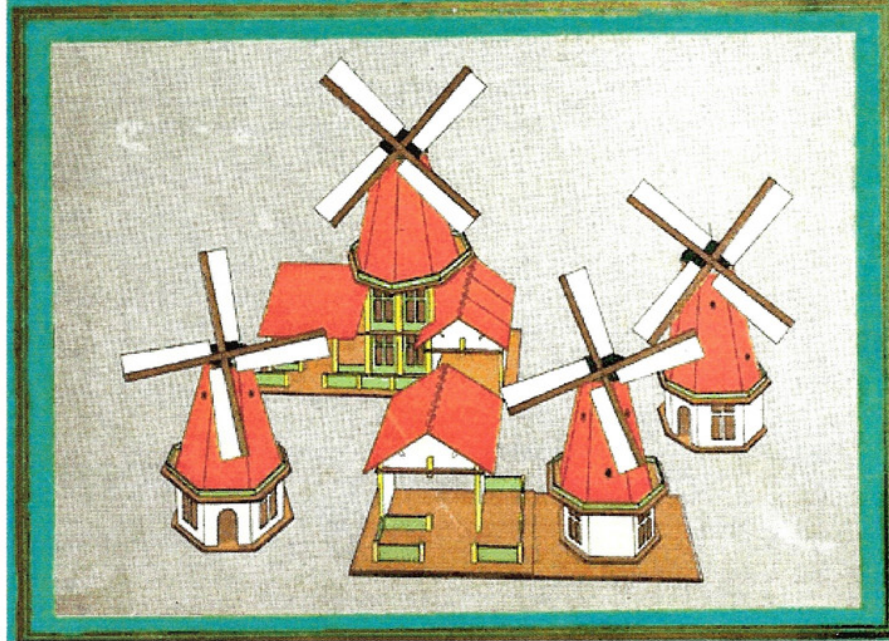

DEUTSCH NEDERLANDS

№. 2

Gereserveerd voor Hollandsche Molen 1

DOZEN

*Mobacco*

MADE IN HOLLAND

PRODUCTION HOLLANDESA

No. 000.

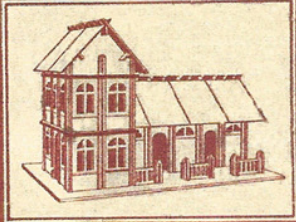

NEDERLANDSCH FABRIKAAT

MADE IN HOLLAND

PRODUCTION HOLLANDESA

MOBACO

NEDERLANDSCH FABRIKAAT

No. 00

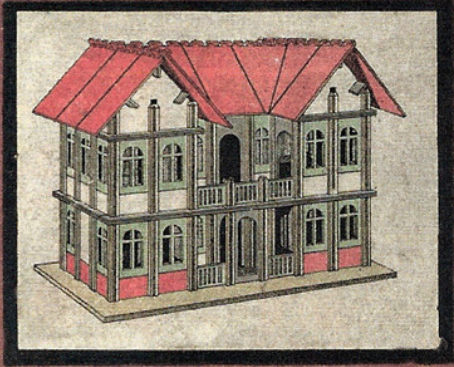

*Mobacco*

PRODUIT NEERLANDAIS

MADE IN HOLLAND

PRODUCTION HOLLANDESA

No. 0



NEDERLANDSCH FABRIKAAT

*Mobacco*

PRODUIT NEERLANDAIS

MADE IN HOLLAND

PRODUCTION HOLLANDESA

No. 0-A

(Deze doos is een aanvulling van doos No. 0 tot doos No. 1)



NEDERLANDSCH FABRIKAAT

*Mobacco*

PRODUIT NEERLANDAIS

MADE IN HOLLAND

PRODUCTION HOLLANDESA

No. 1



NEDERLANDSCH FABRIKAAT

*Mobacco*

PRODUIT NEERLANDAIS

MADE IN HOLLAND

PRODUCTION HOLLANDESA

No. 01

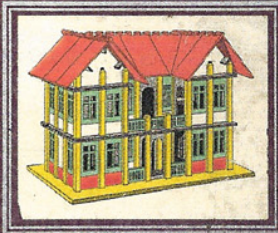

NEDERLANDSCH FABRIKAAT

# Mobaco

No. 1a



**MOBACO**

DORPEN- EN STEDENBOUW - GRONDDOOS  
 THE FINEST BUILDING SET FOR YOUNGSTERS  
 BOITE DE CONSTRUCTION DE VILLES ET DE VILLAGES  
 DÖRFER- UND STÄDTBAUKASTEN  
 CONSTRUCCION DE PUEBLOS Y CIUDADES

**A**

**MOBACO**

DORPEN- EN STEDENBOUW

AANVULLINGSDOOS  
 maakt van doos B doos C

**MOBACO**

DORPEN- EN STEDENBOUW - GRONDDOOS  
 THE FINEST BUILDING SET FOR YOUNGSTERS  
 BOITE DE CONSTRUCTION DE VILLES ET DE VILLAGES  
 DÖRFER- UND STÄDTBAUKASTEN  
 CONSTRUCCION DE PUEBLOS Y CIUDADES

**B**

**MOBACO**

AANVULLINGSDOOS MAAKT VAN DOOS C DOOS D  
 COMPLEMENTARY OUTFIT EXTENDS OUTFIT C TO D  
 BOITE COMPLEMENTAIRE D JUSQU'A D  
 ERGÄNZUNGSKASTEN ERWEITERT C IN D  
 MAS D IGUAL A D

**C-D**

**MOBACO**

THE FINEST BUILDING SET FOR YOUNGSTERS  
 BOITE DE CONSTRUCTION DE VILLES ET DE VILLAGES  
 DÖRFER- UND STÄDTBAUKASTEN  
 CONSTRUCCION DE PUEBLOS Y CIUDADES

**C**

**MOBACO**

AANVULLINGSDOOS MAAKT VAN DOOS D DOOS E  
 COMPLEMENTARY OUTFIT EXTENDS OUTFIT D TO E  
 BOITE COMPLEMENTAIRE E JUSQU'A E  
 ERGÄNZUNGSKASTEN ERWEITERT D IN E  
 MAS E IGUAL A E

**D-E**



# WELK SPEELGOED IS GESCHIKT VOOR ONZE KINDEREN

???

HET LIGT VOOR DE HAND DAT HET IETS MOET ZIJN DAT IN ZICH-  
ZELF DE EIGENSCHAP HEEFT HUN VOLLE AANDACHT BEZIG TE HOUDEN  
EN TEVENS HUN FANTASIE OP TE WEKKEN, M.A.W. HET MOET IETS ZIJN  
WAARIN ZE

LEVEN!

DE SAMENSTELLERS VAN

## MOBACO HET BETERE SPEELGOED

HEBBEN DIT STEEDS VOOR OOGEN GEHOUDEN EN GETRACHT HET  
IDEËLE MET HET TECHNISCH BEREIKBARE ZOOVEEL MOGELIJK TE  
VERBINDEN.

TEGELIJKERTIJD WAREN ZIJ ER OP UIT HET MATERIAAL ZOO TE  
KIEZEN, DAT DE BOUWDOOS, WAT SOLIDITEIT EN DUURZAAMHEID  
BETREFT, AAN HOOGGE EISCHEN VOLDOET  
IN HOEVEERSE ZIJ HIERIN GESLAAGD ZIJN, LATEN WIJ TER BEJOUR  
DEELING OVER AAN HEN, DIE MET

## MOBACO

FABRIKANTE: N.V. PLAATMETAALINDUSTRIE  
VAN MOUWERIK & BAL  
ZEIST, TEL. 3145

KENNISMAKING  
No. 2027

# ONDERDELEN

DE ZEER AANTREKKELIJKE KLEUREN DRAGEN ER IN HOOGTE MAAT  
TOE BIJ ONZE KINDEREN TE INTERESSEEREN EN DAAR ZICH IN EIKEN  
DOODS EEN VOORREKEL DENKROEK BEWISST EN IEDER DEELTJE GENUM-  
MERD IS, KUNNEN ZEELF ZEER JONGE KINDEREN DE AARDIGE MOBACO  
HUISJES BOUWEN.

## MOBACO BOUWDOOZEN

DOOS	INHOUD	INSTRUCTIES VOOR	GEWICHT	PRIJS
000	36 deelen	4 gebouwen	64 K.G.	0,75
00	49	5	0,7	1,50
0	111	8	1,27	2,70
01	160	13	1,88	3,75
1	252	24	2,85	4,95
1a	203	aanverdelings- 40 gebouwen	3,72	7,50
2	454	aanverdelings- 40 gebouwen	6,09	12,--
2a	452	aanverdelings- 40 gebouwen	6,50	21,--
3	800	aanverdelings- 40 gebouwen	11,08	30,--
4	1150	aanverdelings- 40 gebouwen	17,08	42,--
Station 1	153	2 gebouwen	2,47	4,50
2	194	2	5,20	9,--
Garage 1	197	1	2,06	2,75
2	124	1	2,44	3,75
VOORBEELDOENDEK No. 000, St. 1, 2, 3, 4, 5, 6, 7, 8, 9, 10, 11, 12, 13, 14, 15, 16, 17, 18, 19, 20, 21, 22, 23, 24, 25, 26, 27, 28, 29, 30, 31, 32, 33, 34, 35, 36, 37, 38, 39, 40, 41, 42, 43, 44, 45, 46, 47, 48, 49, 50, 51, 52, 53, 54, 55, 56, 57, 58, 59, 60, 61, 62, 63, 64, 65, 66, 67, 68, 69, 70, 71, 72, 73, 74, 75, 76, 77, 78, 79, 80, 81, 82, 83, 84, 85, 86, 87, 88, 89, 90, 91, 92, 93, 94, 95, 96, 97, 98, 99, 100, 101, 102, 103, 104, 105, 106, 107, 108, 109, 110, 111, 112, 113, 114, 115, 116, 117, 118, 119, 120, 121, 122, 123, 124, 125, 126, 127, 128, 129, 130, 131, 132, 133, 134, 135, 136, 137, 138, 139, 140, 141, 142, 143, 144, 145, 146, 147, 148, 149, 150, 151, 152, 153, 154, 155, 156, 157, 158, 159, 160, 161, 162, 163, 164, 165, 166, 167, 168, 169, 170, 171, 172, 173, 174, 175, 176, 177, 178, 179, 180, 181, 182, 183, 184, 185, 186, 187, 188, 189, 190, 191, 192, 193, 194, 195, 196, 197, 198, 199, 200, 201, 202, 203, 204, 205, 206, 207, 208, 209, 210, 211, 212, 213, 214, 215, 216, 217, 218, 219, 220, 221, 222, 223, 224, 225, 226, 227, 228, 229, 230, 231, 232, 233, 234, 235, 236, 237, 238, 239, 240, 241, 242, 243, 244, 245, 246, 247, 248, 249, 250, 251, 252, 253, 254, 255, 256, 257, 258, 259, 260, 261, 262, 263, 264, 265, 266, 267, 268, 269, 270, 271, 272, 273, 274, 275, 276, 277, 278, 279, 280, 281, 282, 283, 284, 285, 286, 287, 288, 289, 290, 291, 292, 293, 294, 295, 296, 297, 298, 299, 300, 301, 302, 303, 304, 305, 306, 307, 308, 309, 310, 311, 312, 313, 314, 315, 316, 317, 318, 319, 320, 321, 322, 323, 324, 325, 326, 327, 328, 329, 330, 331, 332, 333, 334, 335, 336, 337, 338, 339, 340, 341, 342, 343, 344, 345, 346, 347, 348, 349, 350, 351, 352, 353, 354, 355, 356, 357, 358, 359, 360, 361, 362, 363, 364, 365, 366, 367, 368, 369, 370, 371, 372, 373, 374, 375, 376, 377, 378, 379, 380, 381, 382, 383, 384, 385, 386, 387, 388, 389, 390, 391, 392, 393, 394, 395, 396, 397, 398, 399, 400, 401, 402, 403, 404, 405, 406, 407, 408, 409, 410, 411, 412, 413, 414, 415, 416, 417, 418, 419, 420, 421, 422, 423, 424, 425, 426, 427, 428, 429, 430, 431, 432, 433, 434, 435, 436, 437, 438, 439, 440, 441, 442, 443, 444, 445, 446, 447, 448, 449, 450, 451, 452, 453, 454, 455, 456, 457, 458, 459, 460, 461, 462, 463, 464, 465, 466, 467, 468, 469, 470, 471, 472, 473, 474, 475, 476, 477, 478, 479, 480, 481, 482, 483, 484, 485, 486, 487, 488, 489, 490, 491, 492, 493, 494, 495, 496, 497, 498, 499, 500, 501, 502, 503, 504, 505, 506, 507, 508, 509, 510, 511, 512, 513, 514, 515, 516, 517, 518, 519, 520, 521, 522, 523, 524, 525, 526, 527, 528, 529, 530, 531, 532, 533, 534, 535, 536, 537, 538, 539, 540, 541, 542, 543, 544, 545, 546, 547, 548, 549, 550, 551, 552, 553, 554, 555, 556, 557, 558, 559, 560, 561, 562, 563, 564, 565, 566, 567, 568, 569, 570, 571, 572, 573, 574, 575, 576, 577, 578, 579, 580, 581, 582, 583, 584, 585, 586, 587, 588, 589, 590, 591, 592, 593, 594, 595, 596, 597, 598, 599, 600, 601, 602, 603, 604, 605, 606, 607, 608, 609, 610, 611, 612, 613, 614, 615, 616, 617, 618, 619, 620, 621, 622, 623, 624, 625, 626, 627, 628, 629, 630, 631, 632, 633, 634, 635, 636, 637, 638, 639, 640, 641, 642, 643, 644, 645, 646, 647, 648, 649, 650, 651, 652, 653, 654, 655, 656, 657, 658, 659, 660, 661, 662, 663, 664, 665, 666, 667, 668, 669, 670, 671, 672, 673, 674, 675, 676, 677, 678, 679, 680, 681, 682, 683, 684, 685, 686, 687, 688, 689, 690, 691, 692, 693, 694, 695, 696, 697, 698, 699, 700, 701, 702, 703, 704, 705, 706, 707, 708, 709, 710, 711, 712, 713, 714, 715, 716, 717, 718, 719, 720, 721, 722, 723, 724, 725, 726, 727, 728, 729, 730, 731, 732, 733, 734, 735, 736, 737, 738, 739, 740, 741, 742, 743, 744, 745, 746, 747, 748, 749, 750, 751, 752, 753, 754, 755, 756, 757, 758, 759, 760, 761, 762, 763, 764, 765, 766, 767, 768, 769, 770, 771, 772, 773, 774, 775, 776, 777, 778, 779, 780, 781, 782, 783, 784, 785, 786, 787, 788, 789, 790, 791, 792, 793, 794, 795, 796, 797, 798, 799, 800, 801, 802, 803, 804, 805, 806, 807, 808, 809, 810, 811, 812, 813, 814, 815, 816, 817, 818, 819, 820, 821, 822, 823, 824, 825, 826, 827, 828, 829, 830, 831, 832, 833, 834, 835, 836, 837, 838, 839, 840, 841, 842, 843, 844, 845, 846, 847, 848, 849, 850, 851, 852, 853, 854, 855, 856, 857, 858, 859, 860, 861, 862, 863, 864, 865, 866, 867, 868, 869, 870, 871, 872, 873, 874, 875, 876, 877, 878, 879, 880, 881, 882, 883, 884, 885, 886, 887, 888, 889, 890, 891, 892, 893, 894, 895, 896, 897, 898, 899, 900, 901, 902, 903, 904, 905, 906, 907, 908, 909, 910, 911, 912, 913, 914, 915, 916, 917, 918, 919, 920, 921, 922, 923, 924, 925, 926, 927, 928, 929, 930, 931, 932, 933, 934, 935, 936, 937, 938, 939, 940, 941, 942, 943, 944, 945, 946, 947, 948, 949, 950, 951, 952, 953, 954, 955, 956, 957, 958, 959, 960, 961, 962, 963, 964, 965, 966, 967, 968, 969, 970, 971, 972, 973, 974, 975, 976, 977, 978, 979, 980, 981, 982, 983, 984, 985, 986, 987, 988, 989, 990, 991, 992, 993, 994, 995, 996, 997, 998, 999, 1000				10,10 per stuk

BOVENSTAANDE PRIJZEN ZIJN VASTGESTELDE WINKELPRIJZEN  
LOSSE ONDERDELEN BIJ WINKELIERS VERKRIJGBAAR

NEDERLANDSCH FABRIKAAT

1-6-35 Door deze prijslijst vervallen alle vorige noteringen

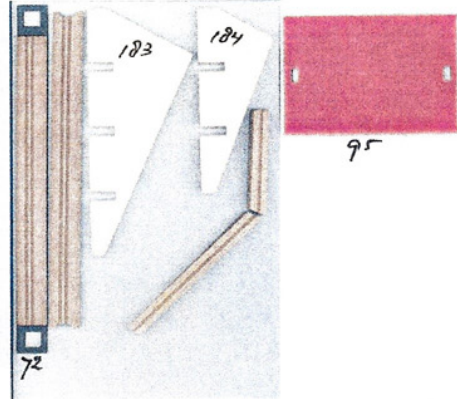
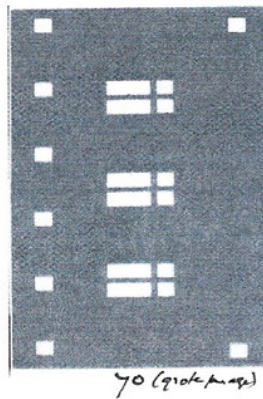
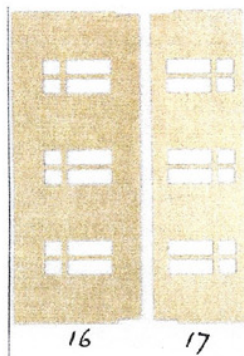
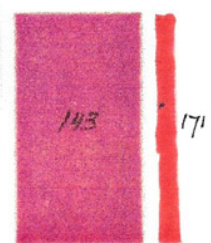
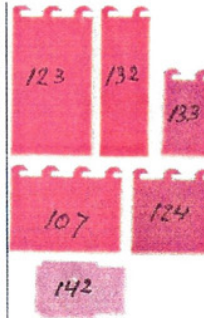
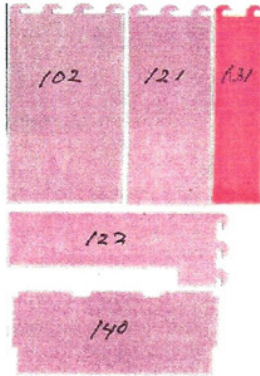
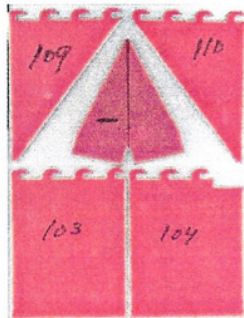
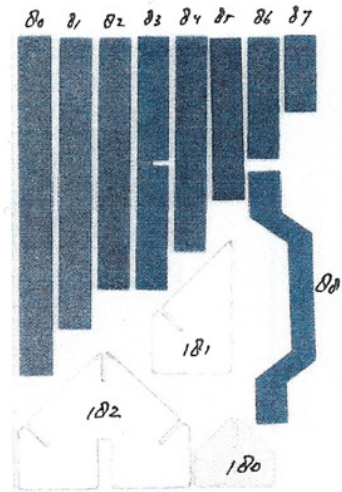
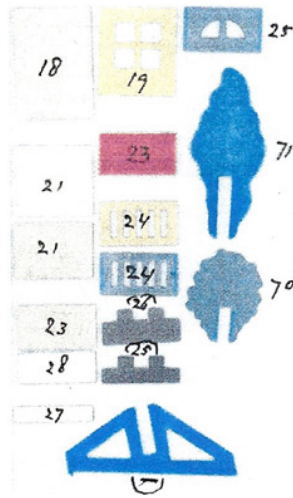
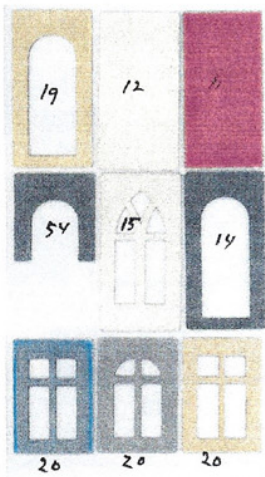
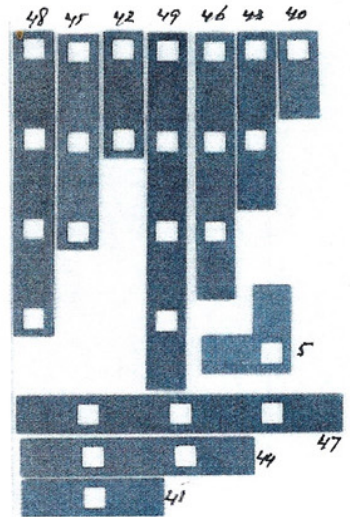
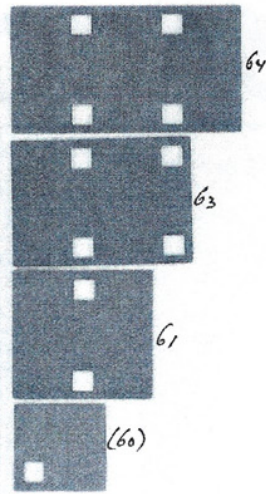
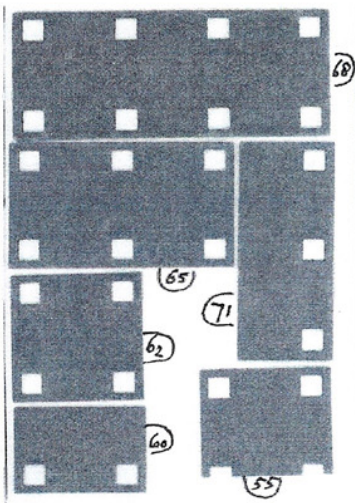

# MOBACO



No.		No.	
1	4	26	4
2	4	27	4
14	1	62	1
20	3	86	1
22	3	107	2
23	2	180	2
24	4	204	1

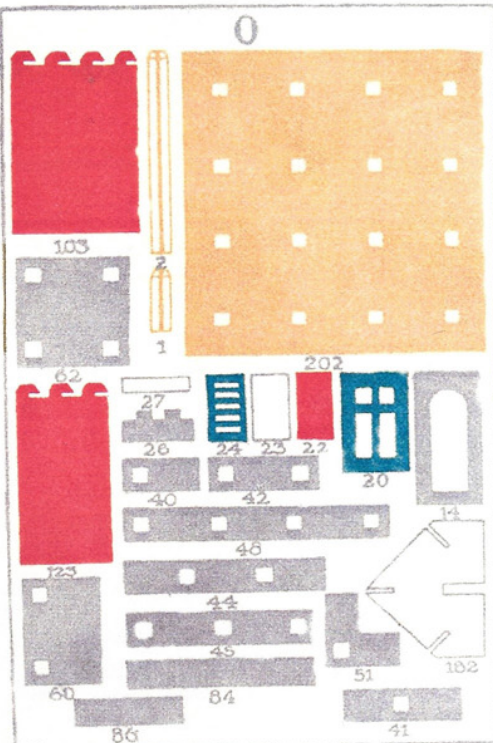

0

103

62

27

26

24

25

22

202

20

14

46

723

44

45

60

84

86

41

102

1

## MOBACO

### 0

No.		No.	
1	12	44	2
2	8	45	4
14	2	48	2
20	9	51	1
22	4	60	2
23	10	62	2
24	12	84	3
26	10	86	3
27	8	103	2
40	4	123	2
41	4	182	2
42	2	202	1

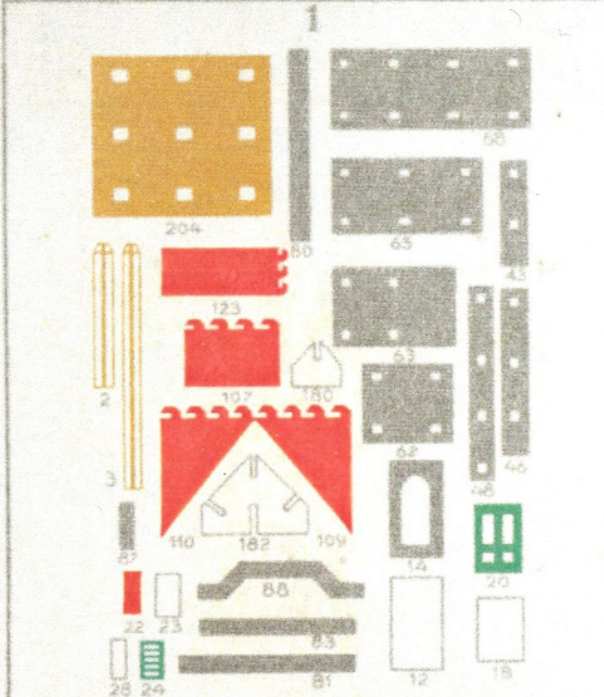

1

204

123

107

180

110

182

109

22

23

28

24

60

65

63

62

46

45

14

20

18

80

83

81

12

18

2

3

87

## MOBACO

### OA

No.		No.		No.	
2	5	43	2	87	2
3	4	46	1	88	2
12	1	48	1	107	3
14	4	62	1	109	4
18	2	63	1	110	4
20	4	65	1	123	2
22	7	68	1	180	2
23	4	80	2	182	4
24	6	81	3	204	1
28	4	83	2		

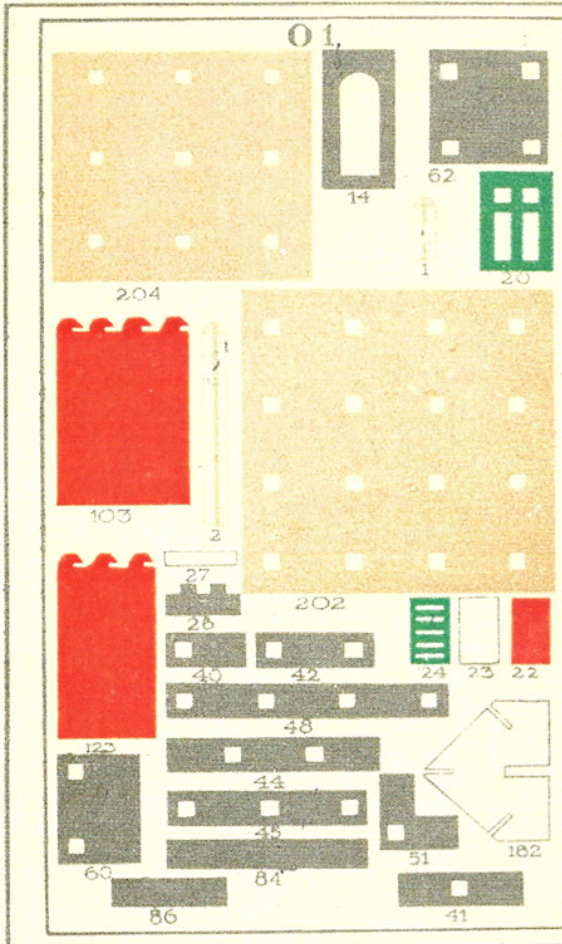

# MOBACO 01

No.		No.	
1	17	44	2
2	14	45	4
14	3	48	2
20	14	51	1
22	6	60	4
23	15	62	4
24	17	84	3
26	14	86	6
27	12	103	4
40	4	123	2
41	4	182	4
42	2	202	1
		204	1

Met deze doos 01 kunnen alle modellen uit de MOBACO-doozen 00 en 0 gebouwd worden, terwijl tevens naar eigen fantasie talrijke bijzonder aardige constructies te maken zijn.

# MOBACO

1

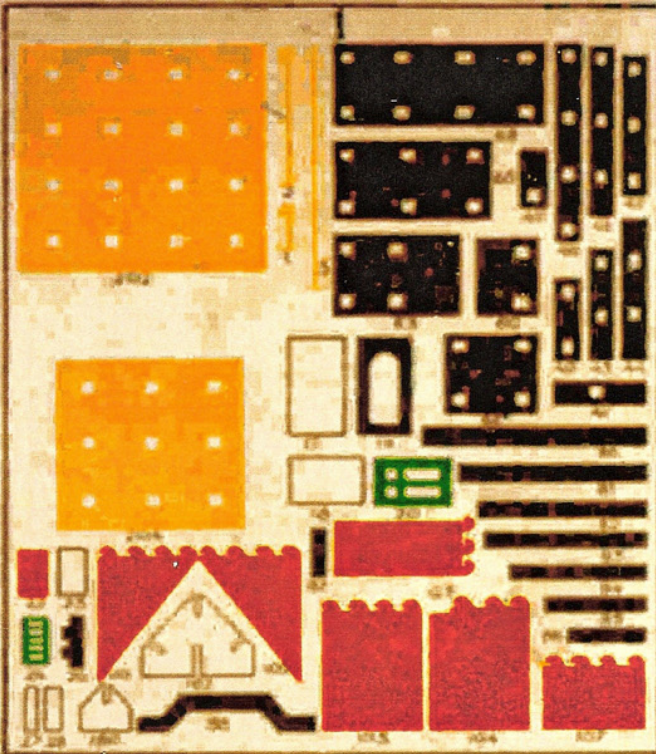

No.	No.	No.	No.	No.	No.
1	12	41	3	83	2
2	13	42	1	84	3
3	4	43	2	86	2
12	1	44	1	87	2
14	5	45	4	88	2
18	2	46	1	103	2
20	13	48	3	107	3
22	11	60	2	109	4
23	14	62	3	110	4
24	18	63	4	123	4
26	4	65	1	180	2
27	4	68	1	182	6
28	4	80	2	202	1
40	2	81	3	204	1

DE NAVOLGENDE ONDERDELEN ZIJN IN DOOS 1A BIJGEGEVOEGD:

No.	AANTAL	No.	AANTAL	No.	AANTAL	No.	AANTAL	No.	AANTAL
2	1	20	1	26	9	60	2	82	2
11	4	21	7	27	9	61	2	85	2
12	3	23	4	40	2	63	4	104	1
14	6	24	6	43	1	65	1	142	1
18	1	25	7	44	1	68	1	181	1

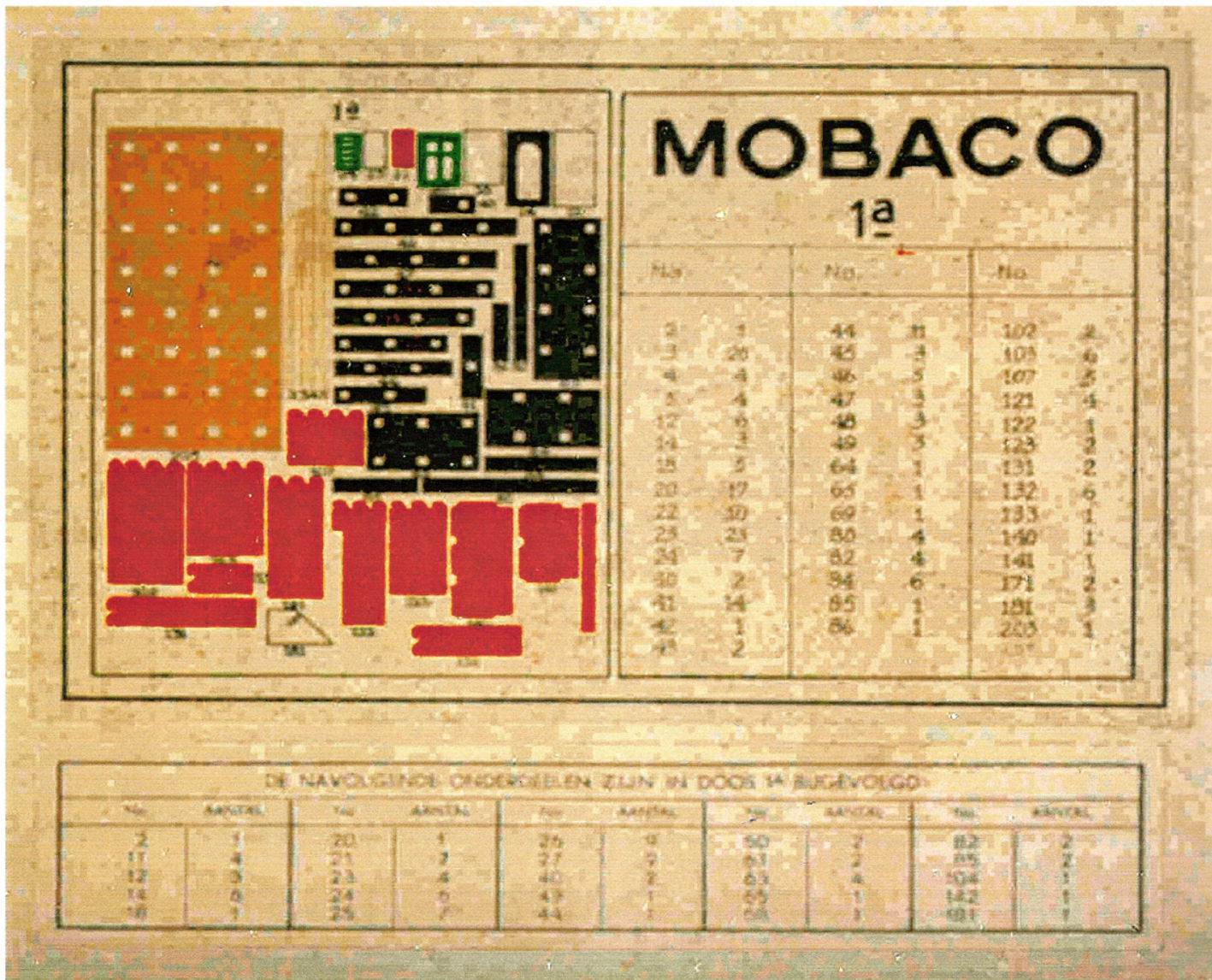

# MOBACO

1a

No.	No.	No.	No.		
2	1	44	11	102	2
3	20	45	3	103	6
4	4	46	3	107	3
5	4	47	3	121	4
12	6	48	3	122	1
14	3	49	3	123	2
15	3	64	1	131	2
20	17	65	1	132	6
22	10	69	1	133	1
23	23	80	4	140	1
24	7	82	4	141	1
30	2	84	6	171	2
41	14	85	1	181	3
42	1	86	1	203	1
43	2				

DE NAVOLGENDE ONDERDELEN ZIJN IN DOOS 1A BIJGEVOEGD

No.	AANTAL	No.	AANTAL	No.	AANTAL	No.	AANTAL	No.	AANTAL
2	1	20	1	26	0	50	2	82	2
11	4	21	2	27	0	83	2	85	2
12	3	23	4	40	2	84	4	104	1
14	3	24	5	43	1	85	1	142	1
15	1	25	7	44	1	86	1	181	1

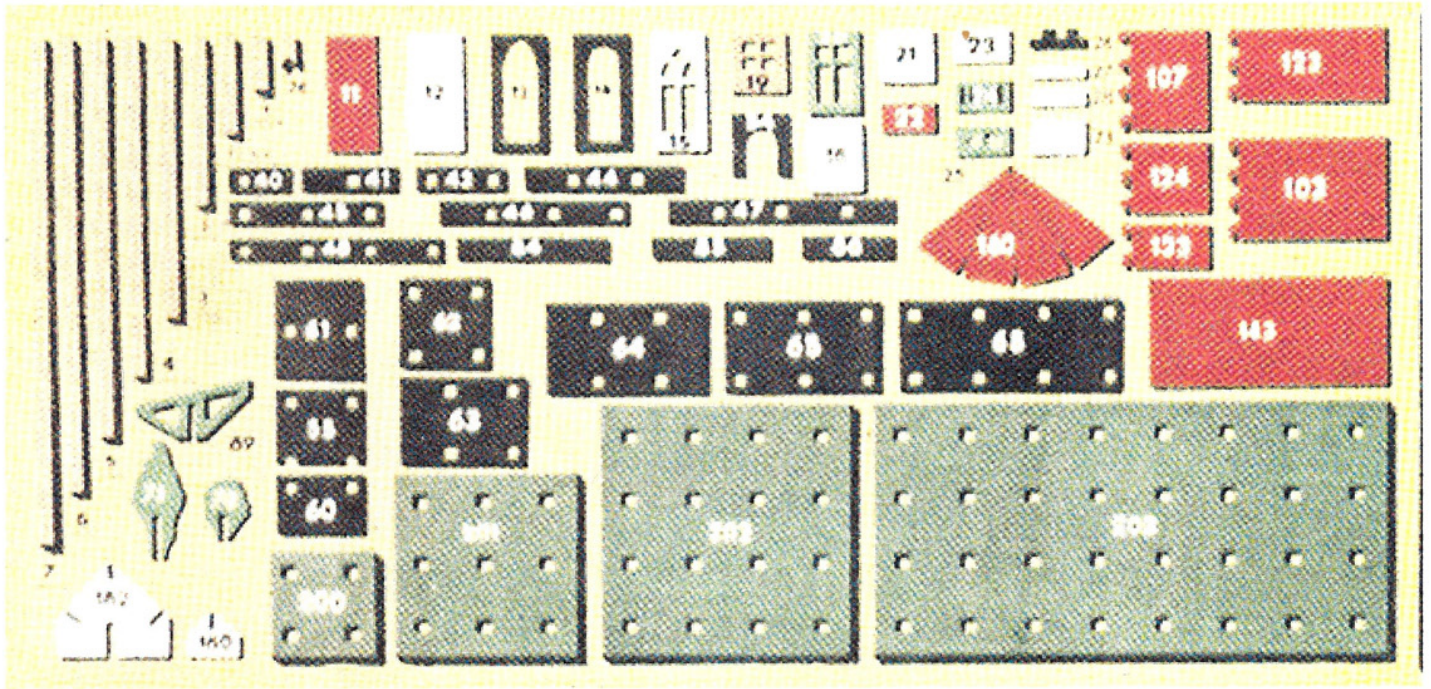

CONTENTS OF THE VARIOUS MOBACO OUTFITS  
 CONTENIDO DE LAS DIFERENTES CAJAS MOBACO  
 TABLE DES ACCESSOIRES DE MOBACO  
 TAFEL MIT DEN VERSCHIEDENEN MOBACO TEILEN  
 INHOUD DER VERSCHILLENDE MOBACO DOZEN

No.	A	AB	B	BC	C	CD	D	DE	E
1	2	4	6	2	8	4	12	—	12
1 1/2	4	2	6	2	8	4	12	—	12
2	—	—	—	4	4	4	8	—	8
3	—	—	—	—	—	—	—	4	4
11	—	—	—	—	—	1	1	1	2
12	—	—	—	—	—	1	1	1	2
14	—	—	—	—	—	—	2	2	4
15	—	—	—	2	2	—	2	2	4
18	—	—	—	—	—	—	—	2	2
19	1	1	2	1	3	3	6	—	6
20	—	—	—	—	—	—	4	4	4
21	—	—	—	—	—	—	2	2	2
22	2	1	3	1	4	2	6	4	10
23	2	1	3	1	4	4	8	4	12
24	2	4	6	2	8	4	12	4	16
25	—	—	—	1	1	3	4	—	4
26	—	4	4	—	4	8	12	—	12
27	—	4	4	—	4	4	8	—	8
28	—	—	—	—	—	4	6	—	6
40	—	—	—	—	—	—	—	4	4
41	—	1	1	—	—	—	—	4	4
42	—	—	—	—	1	1	2	—	2
44	—	—	—	—	—	—	—	2	2
45	—	—	—	—	—	—	—	4	4
48	—	—	—	—	—	—	—	2	2
54	1	1	2	—	2	1	3	—	3
55	—	1	1	—	1	1	2	—	2
60	—	1	1	—	1	1	2	—	2
62	1	—	—	—	1	1	2	1	3
63	—	—	—	—	—	—	1	—	1
65	—	—	—	—	—	—	—	1	1
68	—	—	—	—	—	—	—	1	1
70	1	—	—	—	1	—	1	2	3
71	—	—	—	—	1	—	1	2	3
73	—	—	—	1	1	—	1	—	1
76	1	1	2	—	2	—	2	2	4
84	—	1	—	—	1	—	2	2	4
85	—	—	—	—	—	1	2	—	2
86	—	1	—	—	1	—	2	—	2
89	—	—	—	—	—	2	2	—	2
103	—	—	—	—	—	—	—	2	2
107	2	—	2	—	2	2	4	—	4
123	—	—	—	—	—	—	—	2	2
124	—	2	2	—	2	2	4	—	4
133	—	—	—	—	—	4	4	—	4
143	—	—	—	—	—	—	—	1	1
160	—	—	—	1	—	—	—	1	2
180	2	2	4	—	4	—	4	—	4
182	—	—	—	—	—	—	—	2	2
200	—	—	—	—	—	—	—	1	1
201	1	1	2	—	2	—	2	—	2
202	—	—	—	—	—	—	—	1	1
203	—	—	—	1	—	—	—	—	1

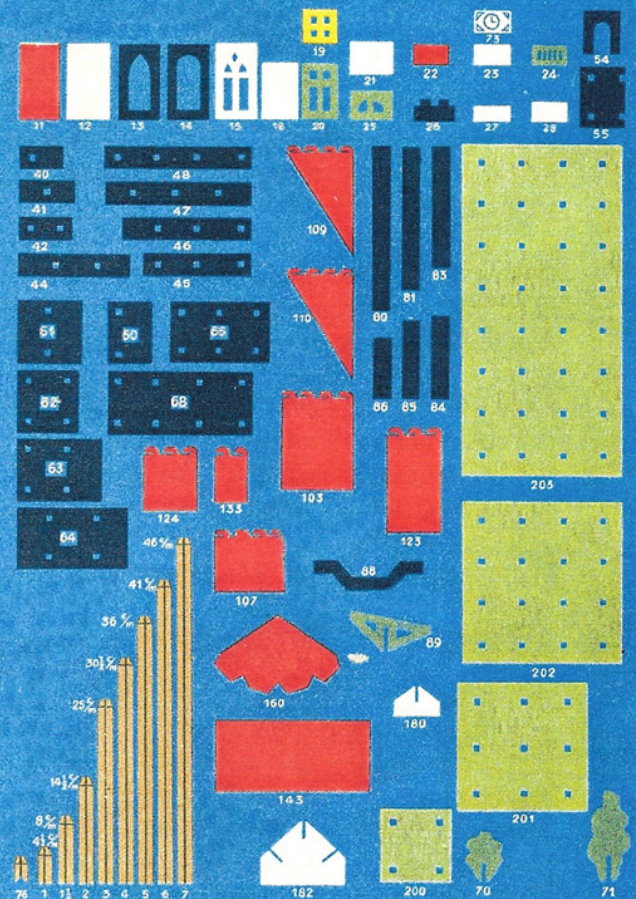

COPYRIGHT: HAUSEMANN & HOTTE N.V. AMSTERDAM



# ARTIKEL LINNEKER OP INTERNET

## Mobaco

This has to be one of my favourite sets! Manufactured by the Dutch company Mobal between 1920 and 1960 in Zeist, Holland. Mobal was a manufacturer of sheet metal products but a few times each year would clean their machines and make the Mobaco parts!

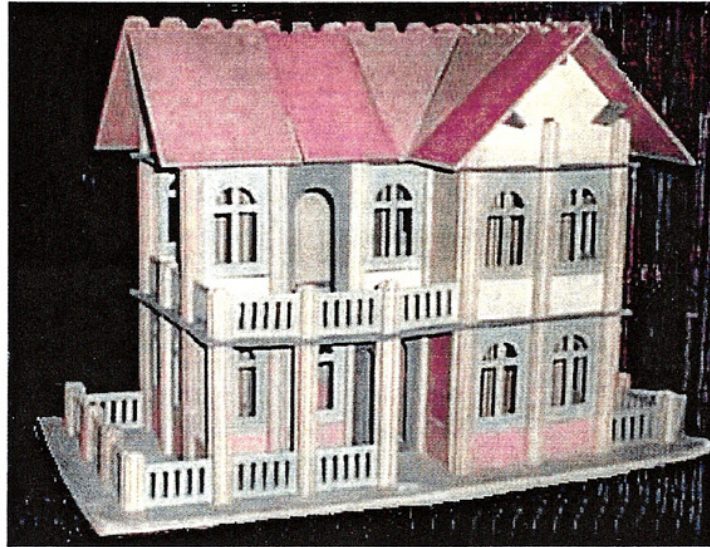

Most parts did not change much over the years with the notable exception of the green window, part no. 20. The earlier windows were rounded at the top, as can be seen in the picture, the later ones were square.

During the 1950's the sets were marketed by a company called Jumbo. Typically they were supplied in red boxes in a range of sizes from A to E. Sets could be upgraded from one size to the next - so set A could be converted to set B by the purchase of the intermediate set AB.

I like a few others have thought that the sets were manufactured by a company called Handelsmerk - this could not be further from the truth. In fact two words appear on the building plans booklet - 'Gedeponcerd Handelsmerk'. The translation actually appears alongside, though we didn't realise, it means 'Registered Trademark' and nothing else!!

Many thanks to Barend Westerveld in Holland for assisting with this information.

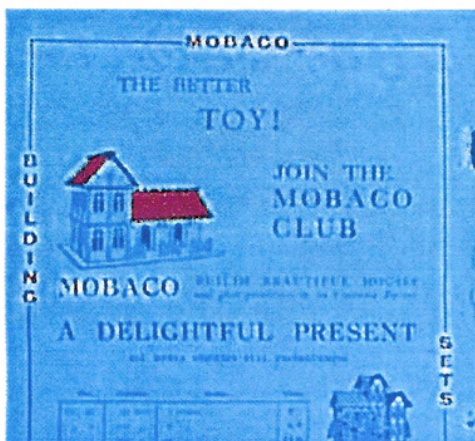

This is a magazine advert dating from 1928.

In some respects this set is very similar in its principles of construction to Bayko. It comprises a large card/fibre base board which has a matrix of square holes into which wooden pillars are placed. Panels representing walls, windows, doors or balustrades are then slid between the pillars to create the building which is then finished by the roof sections. The roof system is different to Bayko in that many designs are possible by the use of miniature purlins, ridgeboards and a variety of flat roof sections.

The impressive cover for the number 2 set instructions.



*Last Update: 23rd January 1998  
Web Master: G. Lilleker - [geoff@lilleker.u-net.com](mailto:geoff@lilleker.u-net.com)  
© copyright 1998 G. Lilleker*

# DE BULLENBURG HERREZEN - 2003



## INHOUD

INLEIDING .....	-3-
VOORBEELDENBOEK 000 .....	-6-
VOORBEELDENBOEK 0-1 .....	-7-
VOORBEELDENBOEK 00-0-1 .....	-8-
VOORBEELDENBOEK 2 .....	-23-
VOORBEELDENBOEK-A-E .....	-40-
GARAGE .....	-52-
MOLEN .....	-56-
DOZEN .....	-58-
ONDERDELEN .....	-60-
ARTIKEL LINNEKER .....	-68-
DE BULLENBURG HERREZEN - 2003 .....	-70-